

# Putting Energy Into Stewardship

*ENERGY STAR® For Congregations Guide*



EPA would like to thank Aspen Systems Corporation for its contribution to this publication.

This report was prepared as an account of work sponsored by an agency of the United States Government. Neither the United States Government nor any agency thereof, nor any of their employees, makes any warranty, express or implied, or assumes any legal liability or responsibility for the accuracy, completeness, or usefulness of any information, apparatus, product, or process disclosed, or represents that its use would not infringe privately owned rights. Reference herein to any specific commercial product, process, or service by trade name, trademark, manufacturer, or otherwise does not necessarily constitute or imply its endorsement, recommendation, or favoring by the United States Government or any agency thereof. The views and opinions of authors expressed herein do not necessarily state or reflect those of the United States Government or any agency thereof.

This guidebook is intended to present a realistic look at energy-efficiency practices but cautions that specific references to costs or performance characteristics are “typical.” Actual values may vary depending on location, climate and manufacturer. The guidebook documents various energy-efficiency options for saving energy in congregations, however, the EPA in no way recommends the use of energy-efficiency products or practices that are contradictory to your personal beliefs.



**Welcome**

# Welcome

## Thanks For Your Commitment To Energy Stewardship

**W**hen your congregation pays its utility bills each month, you probably don't care too much about kilowatt-hours or therms. You want heat, air conditioning, lighting, and other services at the lowest possible cost. *Putting Energy Into Stewardship* can help you get the most from your equipment and facility and decrease your operating costs. We call this energy optimization; you'll just call it smart stewardship of money and natural resources.

Most religious traditions teach stewardship of financial and natural resources. Energy efficiency is an excellent means of achieving both of these objectives at the same time, because energy saved is both money saved and pollution prevented.

With so many pressing and legitimate demands on your congregation's financial resources, does it make sense to pay more for energy? Of course not—and it also doesn't make sense environmentally to use more energy than necessary. Ineffective energy use wastes the Earth's precious natural resources and causes pollution. Many congregations, just like yours, are becoming better resource stewards.

Energy efficiency recovers the money you would otherwise spend each month on wasted energy. These dollars saved can support your congregation's mission and charity while you simultaneously help prevent pollution.

Every time a light, a computer, or an air conditioner is turned on, a power plant consumes some type of fuel to generate electricity. Most of the time, a fossil fuel is burned to generate power, and the process releases emissions and pollution into the atmosphere and elsewhere in the environment. These pollutants cause acid rain and smog, and most scientists agree these emissions are changing our global climate. Human health—as well as nature's complex ecosystem—also is affected directly.

Since the 1970s, tremendous technological advances have been made in building systems and controls. As a result, you can often get off-the-shelf building technologies that provide more comfort for significantly less money than you are currently spending.

## Let's Look At Some Examples

Say you have several incandescent floodlights mounted outside your building for security. Replacing them with high-intensity discharge (HID) fixtures could save 80 percent of the electricity while increasing the light level (see page 44). That can save you big money and improve building security. Installing photocell controls will ensure that the lights always will be on at night to deter vandals or burglars who may be tempted to take advantage of the shadows.

Have you ever experienced eye fatigue or headaches from working under the glare of older fluorescent lights? Do



*Get more work done and spend less by upgrading your existing lighting with newer technologies.*



Kenneth Gair, facilities manager for the Sligo Adventist School, invested \$44,728 (and received \$27,527 in utility incentives) to perform upgrades on the school building. With a 1.5-year overall payback on the energy investments, he saved enough money to build the kids a new playground and return \$11,136 a year to the school. See page 47 for details.

you have trouble viewing your computer monitor because the lighting in the room is too bright? Upgrading your existing lighting with newer technologies can increase visual comfort for congregation members, enhance interior appearances, and allow your congregation to experience a more enjoyable service. Costs may be 20 to 50 percent less than with old equipment.

ENERGY STAR® for congregations will help you apply solutions such as these to your facilities so you can save money, optimize energy use, and help protect the environment. As an ENERGY STAR partner, you will have access to unbiased information on building technologies and the upgrade process.

For more information, call us toll-free at 1-888-STAR-YES (1-888-782-7937) or visit our Web sites at [www.epa.gov/congregations](http://www.epa.gov/congregations) and [www.energystar.gov](http://www.energystar.gov).

## Where To Find What You Need In This Guide

We realize your time is very valuable, so we've designed this guide to get you the information you need quickly. This section is your key.

**Section 1, "Getting The Job Done,"** gives you practical advice on how to overcome the technical, financial, and managerial hurdles that you may encounter on the path to reducing your utility costs through energy optimization. In this section, we give you proven strategies to identify the best energy upgrades for your congregational facilities. We also discuss how you can finance these upgrades, and we give you time-tested guidelines for selecting contractors to help you get the job done. You can use the tables provided to compare your energy use and costs with those of similar congregations in your region.

**Section 2, "Technical Support,"** describes the many technologies that can improve your energy efficiency. You probably expect that only lighting, heating, cooling, and water heating are covered in-depth; however, you may be a little surprised to find out how much money selecting the right office equipment can save. And we include a discussion of techniques to optimize your paper use that will save you money while preserving our nation's forests.

Throughout **Section 2** we identify simple measures that you can do yourself in just a few minutes. And for more involved upgrades, we explain the solutions and the terms so that you can be a smarter shopper when interacting with contractors and suppliers.

**Section 3, "Supporting Material,"** contains a glossary that will help you understand unfamiliar terms and new technologies. This section also has a checklist of ways to improve your facility's energy efficiency and a shopping list of things to look for when buying or leasing a building.

Your facility could be featured in an ENERGY STAR Success Story, and your congregation can be publicly recognized for exemplary environmental stewardship.

---

*Let us publicize your success!*

## Additional ENERGY STAR Services

Every ENERGY STAR congregational partner has access to a full range of technical materials and services. These include seminars, workshops, and written materials on energy-efficiency upgrades, as well as brochures and promotional information that you can use to highlight your participation to your congregation members.

Feel free to call the toll-free hotline (1-888-STAR-YES) at any time to find out about additional materials and publications. After reviewing the relevant publications, you may discover that you can do certain projects in-house using the professional skills of congregation members; if you find your congregation lacks members with the necessary professional abilities, you may decide to enlist the help of outside professionals.

Either way, we will help you become a smarter buyer and ask the right questions. If you have access to the World Wide Web, we invite you to visit the ENERGY STAR for congregations Web site at [www.epa.gov/congregations](http://www.epa.gov/congregations). From there you can explore the materials and services available, access new information not in this guide, and link to energy-efficiency sites throughout the Internet.

## Selected Reading

### **I have no time.**

Read “Finding The Time” and “Learning About Energy Efficiency” in **Section 1**. A consultant or an ENERGY STAR product and service provider will be able to identify upgrade options for you with only a limited investment of your time. (ENERGY STAR product and service providers are firms that sell products and/or services for energy-efficiency upgrades. These companies may be found at [www.epa.gov/congregations](http://www.epa.gov/congregations) or by calling 1-888-STAR-YES.)

### **I have access to in-house technical help.**

Read **Section 1** and then pass this guide to your staff. One week later, schedule a meeting to review the technologies and upgrades that might be appropriate for your congregation and to establish a preliminary timeline.

### **I don't have access to technical skills and would likely contract out all work.**

Read or scan this entire guide so you can determine which equipment to focus on and whom to call for help.

# Contents

*Putting Energy Into Stewardship: ENERGY STAR® For Congregations Guide*



## **SECTION 1: Getting The Job Done ..... 1**

Finding The Time .....	3
Getting The Money .....	5
Learning About Energy Efficiency .....	7
Making A Good Building Even Better .....	11
Selecting A Contractor .....	15
Benefiting From Energy Savings As A Tenant .....	19
Verifying Savings .....	21
ENERGY STAR Support For Congregations .....	23

## **SECTION 2: Technical Support ..... 25**

Financial Analysis .....	27
Prioritizing Your Projects .....	31
Lighting Part I: Concepts .....	33
Lighting Part II: Upgrades .....	39
Building Tune-Up .....	49
Office Equipment .....	51
Paper .....	55
Water Heaters And Water Use .....	57
Refrigeration .....	63
Building Construction .....	65
Heating And Cooling .....	71
Other Ideas For Energy Stewardship .....	77

## **SECTION 3: Supporting Material ..... 79**

Glossary .....	81
Energy-Efficiency Quicklist .....	89
ENERGY STAR Shopping List For Congregations .....	91



**Getting The  
Job Done**

# Finding The Time



**W**e understand how important your time is. We're also convinced that energy-efficiency upgrades are well worth your consideration because of the savings and improved comfort they bring.

## Getting Started With Few Hassles

Here are strategies to jumpstart your energy savings with a limited investment of your time.

- Ask your utility if it offers free or inexpensive energy surveys.
- Ask your congregation if members are professionally skilled in the areas where energy can be saved.
- Invite lighting contractors and heating, ventilating, and air-conditioning (HVAC) contractors to your facility to suggest upgrades.
- Leverage your time by drawing on the expertise of ENERGY STAR product and service providers. Call 1-888-STAR-YES for your nearest provider, or see the Energy Services and Products Directory on the ENERGY STAR Web sites ([www.epa.gov/congregations](http://www.epa.gov/congregations) and [www.energystar.gov](http://www.energystar.gov)) for a directory of contractors.
- Discuss the project with a congregation member who might coordinate and manage your project, or consider contracting with an energy professional.
- Select turnkey services from an Energy Services Company (ESCO); see page 8.

- Delegate responsibilities to your coordinator if you discover a particular project is taking more of your time than you can afford.

## The Cost Of Delay

While we often think of upgrade projects in terms of how quickly the investment is paid off through the savings, we usually don't recognize the other side of this equation. For each month or year that you delay your upgrade projects, you lose potential savings.

*Many consulting engineers, utilities, and ENERGY STAR® product and service providers offer their services to review proposals, oversee contractors, and attend project meetings.*

Consider a congregation with an annual energy expense of \$25,000. If a comprehensive upgrade program could reduce energy use by 30 percent, this congregation could save \$7,500 per year. Assume that the cost of implementing these measures results in a 3-year simple payback, which is typical.



# Getting The Money



**T**he key issue is, how do you pay for the upgrades? Not a problem, in most cases. Energy-efficiency upgrades make such good financial sense that many traditional and nontraditional resources can provide you and your congregation with a positive cash flow.

For inexpensive projects, you'll want to fund your upgrades with internal funds. The overhead costs of financing are too high for small projects. This is the best way to keep payback time low and return on investment high.

For larger jobs, some congregations may not have the convenient cash reserves or revolving credit that large businesses do. Cash flow limitations can make capital funding from reserves simply impossible. In such situations, financing is the only way the project can be implemented. Fortunately, a wide variety of sources and mechanisms has evolved over the past few years to help smaller facilities maintain a positive cash flow while implementing energy-efficiency projects.

## ENERGY STAR For Congregations Finance Directory

Resources are available through ENERGY STAR for congregations to help you find financing. EPA does not endorse individual lenders or lessors, but we do provide an ever-growing list. If you have Internet access, our Web site at [www.epa.gov/congregations](http://www.epa.gov/congregations) features a finance directory (click on "finance directory") that provides direct access to lenders that offer

such loans and leases. It also contains some Web links, and you can download the text of the finance directory from the Web site. The printed version of the finance directory also may be requested by calling ENERGY STAR for congregations at the toll-free ENERGY STAR hotline (1-888-STAR-YES).

The ENERGY STAR finance directory offers a variety of financing options including:

- **Your religious organization.** Many denominations have established funds for facility improvement or construction. Ask your congregational leadership to check.
- **Supplier loans.** Many suppliers offer financing in combination with installation of their equipment. Make sure the interest rate is comparable to what you can get elsewhere.
- **Utility loans.** Your utility may have a low-interest loan program or other financing to underwrite energy-efficiency projects.
- **State loans.** Your state energy office may be aware of alternative sources of loans—and possibly grant monies—for congregations like yours.

## Performance Contracting

Financing your project yourself through a cash purchase or a loan requires you to shoulder all the responsibility for the project's success. Performance contracting, available primarily through ESCOs (see page 8), is an alternative way to finance energy-efficiency projects. You receive a lower level of cost savings at first, but have insurance that your

---

*The ENERGY STAR® finance directory makes it easy to find conventional and innovative lenders for energy upgrade projects ([www.epa.gov/congregations](http://www.epa.gov/congregations)).*

actual savings will meet your expectations. Performance contracts typically are negotiated with no upfront cost to the building owner; money realized from energy savings goes to pay project expenses. A detailed explanation of performance contracts is found in *Financing Your Energy-Efficiency Upgrade*, EPA 430-B-97-003. Call the ENERGY STAR hotline at 1-888-STAR-YES for this or other publications.

### Reinvestment Of Savings

ENERGY STAR for congregations emphasizes a staged approach to energy investment projects (see page 31). You can use the cost savings from your first project to fund your second project, and so on.

### Tax Implications

While your congregation is tax exempt, your members also may want to upgrade the efficiency of their businesses. Legislation in summer 1996 extended the ability of businesses to deduct equipment upgrades as an expense. This can save them money by taking capital costs that normally would be amortized and deducted from declared profit over several years and advancing the costs into a current year tax deduction. We suggest that they contact their accountants for more information on how upgrade projects can reduce their taxes and improve their cash flow.

# Learning About Energy Efficiency



**Y**ou may not know a lot about the intricacies of motors, lighting, or air conditioning. You may be reluctant to take on the challenges of building upgrade projects, especially when your existing equipment works just fine. We will help you successfully implement upgrades by relying heavily on energy professionals and ENERGY STAR resources. We will help you through the process, and we can answer your most difficult questions.

## Energy-Efficiency Basics

Building technologies have advanced at a striking pace during the past decade. If your building's lighting and heating/cooling systems are more than 10 years old, you could potentially see big savings—up to 50 percent—by upgrading. Key opportunities are described below.

**Lighting.** Even though the old-fashioned light bulb is still the symbol of innovation, those incandescent bulbs consume 75 percent more electricity than compact fluorescent bulbs. The higher cost of compact fluorescent bulbs is quickly recovered through energy savings and lamp longevity. New technologies are employed to reduce the energy use of fluorescent fixtures. And occupancy sensors, which turn lights off in unoccupied areas, have become surprisingly inexpensive (see page 46). Look around your building. If you use fixtures that are more than 10 years old, your building is a good candidate for a lighting upgrade.

**Building Tune-Up.** Get your building back to its original performance. See page 49 for more information.

### Office Equipment And Paper Use.

Selecting ENERGY STAR labeled equipment when you purchase new computers or office equipment and encouraging a few simple practices among your volunteers or employees will yield energy savings with absolutely no investment cost. See pages 51 and 55 for more information.



## Consider Some Of The Traditional Myths About Equipment And Energy Use<sup>1</sup>

**Myth:** Leaving computers on helps them last longer.

**Reality:** Today's computers do not suffer from being turned on and off thousands of times. In fact, turning computers off when they're not being used lowers the amount of dust buildup inside, which helps them last longer while saving you money.

**Myth:** Energy costs are an insignificant part of total expenses.

**Reality:** Energy savings can always be used to fund materials, supplies, and publications. In addition to your reduced utility bills, improved congregant comfort is common after building upgrades.

**Myth:** Fluorescent lights last longer if not turned on and off.

**Reality:** Switching fluorescent lights on and off does slightly shorten their life. However, any time lights are not needed for more than about 10 minutes, you save more money by turning them off than by leaving them on.

**Myth:** I should replace old equipment with more efficient versions only as the old equipment breaks.

**Reality:** With some new technologies, such as T-8 fluorescent lights (20 to 60 percent savings) or light emitting diode (LED) exit signs (up to 90 percent savings), there's just no reason to wait. You can start saving money on energy and maintenance costs right away.

<sup>1</sup> ASHRAE Journal, January 1997.

---

*Unique opportunities for energy savings are available for each congregation.*

**Water Heating And Water Conservation.** You may be paying more than you need to for water use or water heating. Learn more starting on page 57.

**Refrigeration.** Check your seals regularly and specify high-efficiency evaporator fans when you buy new systems. These and other operations and maintenance guidelines will keep your refrigeration equipment working at peak efficiency. See page 63 for additional ideas.

**Building Construction.** A review of the steps to upgrade your building's walls, roof, and windows to get the most comfort from your heating and cooling units starts on page 65.

**Heating And Cooling.** Inexpensive modifications such as installing programmable thermostats and cleaning your filters often can significantly reduce your heating or cooling costs.

Thinking of replacing your old system? See page 71 to explore the options before you buy, because it may be worth the extra cost. If your existing system is old enough, it may be cost-effective to replace it with a new one immediately.

**Other Opportunities.** Each congregation has unique opportunities for energy savings based on the particular equipment it uses. Many of these measures are discussed starting on page 77; you can also call the ENERGY STAR hotline at 1-888-STAR-YES for information on measures not covered in this guide.

---

## Installation Support

**Lean on outside contractors for expertise and installation. Available resources include ESCOs and conventional contractors:**

- **Energy Services Companies (ESCOs)** offer turnkey services that are excellent alternatives for larger projects. The company will perform a survey (usually free) to identify savings opportunities and will arrange financing, coordinate contractors, and perform all project management. Often, these projects are financed as performance contracts, where the ESCO receives a portion of the savings generated by the project. The National Association of Energy Services Companies (NAESCO) can refer you to the ESCOs in your area; call (202) 822-0950 or visit the Web site at [www.naesco.org](http://www.naesco.org).
- **Lighting contractors** will be familiar with all aspects of lighting design and can conduct lighting surveys, recommend replacements, and calculate energy and cost savings. Lighting contractors are the best choice when the project is high profile or requires significant lighting redesign.
- **Electrical contractors** have skills installing motors, modifying equipment, and performing straightforward lighting upgrades.
- **Mechanical contractors** specialize in the heating, cooling, and ventilating systems at a facility. They can coordinate the work of subcontractors and interface with installers of Energy Management Systems (EMSs) if required.
- **Controls contractors** specialize in the automatic controls for heating, cooling, ventilating, lighting, and emergency systems. Installation of a central computerized control system with advanced energy savings functions (also known as EMS) is cost effective for many facilities.
- **Operations and maintenance contractors** will perform routine preventive maintenance that can extend equipment life and reduce energy use.

## Lean On Experts For Advice

The type of help you will need to start your upgrade projects depends on the amount and skill level of in-house support, the type of project, and the size of the project.

To begin, you may need the help of a consultant or an energy surveyor to identify upgrade opportunities. If your in-house support is extremely limited, you may need some level of management or oversight by a consultant other than the contractor performing the work. Typically this is money well spent because, just like hiring a professional accountant to prepare your tax returns, professional consultants or surveyors often save you more money and provide fast and efficient results that allow you to make knowledgeable choices concerning energy-efficiency upgrades.

Start with a free energy survey where available. Call your electric or gas utility. Nearly half of the country's biggest utility companies offer free or subsi-

dized energy surveys for commercial customers to identify energy-efficiency opportunities. These surveys may not identify fuel-switching opportunities that convert you from the sponsoring utility's product, but otherwise they are an excellent and objective way to get started. Some utilities give free compact fluorescent lamps to their customers.

If you don't have any luck there, call some electrical or heating, ventilating, and air-conditioning (HVAC) contractors for free walk-through surveys. Just be aware that the contractor's agenda for such a survey will include a sales pitch; if you don't have a long-term relationship with your contractor, you will want to consider capital-intensive recommendations carefully.

If you don't have a contractor, call 1-888-STAR-YES and ask for the nearest ENERGY STAR product and service providers. These companies have received training in strategies to upgrade building systems to optimize performance.

For large projects outside your realm of expertise, consider hiring consultants to prepare bid documents or to verify the work of contractors. As a rule of thumb, it is worthwhile to have a management investment of 3 to 10 percent of the project cost so an independent expert can oversee major projects. This premium doesn't detract much from your payback and acts as a good insurance policy. Look in the Yellow Pages of your phone book under Engineering Consultants or similar headings, or call 1-888-STAR-YES for the name of your nearest ENERGY STAR product and service provider. For information about financial or technical assistance that is available for energy-efficiency upgrades, call your local energy utility or your state energy office.

## ENERGY STAR Labeled Products

ENERGY STAR labeled products use less energy than other products, save you money on utility bills, and help protect the environment. Look for the ENERGY STAR label on:

- Household appliances
- Compact fluorescent light bulbs
- Exit signs
- Home electronics
- Office equipment
- Heating and cooling products
- Homes
- Windows
- Residential lighting fixtures
- Transformers
- Roof products
- Insulation
- Products in development



This Web site ([www.energystar.gov/](http://www.energystar.gov/)) provides lists of ENERGY STAR qualified products and a store locator to help you find qualified products at a retailer near you. ENERGY STAR labeled products are made by all major manufacturers and are available at stores everywhere.

## The Second Price Tag: Energy Efficient Appliances Cost Less To Own

Although energy-efficient models sometimes cost more to purchase, any extra upfront cost often can be made up with savings on your utility bill. One helpful way to figure out if buying an ENERGY STAR labeled product makes sense for you is to think of two price tags.

The first price tag is the purchase price that you pay at the store when you buy the product.

The second price tag is the cost to operate the product over its lifetime. You pay to operate the product every

month for as long as you own the appliance. You might be surprised to see how much it can cost to own a product that seems like a good deal upfront. Also, check with your local utility—many offer rebates on the purchase of ENERGY STAR labeled products.

## Where Can I Learn More?

For more information on energy technologies contact:

- Air Conditioning Contractors of America (ACCA): (202) 483-9370; [www.acca.org](http://www.acca.org)
- American Consulting Engineers Council (ACEC): (202) 347-7474; [www.acec.org](http://www.acec.org)
- American Society of Heating, Refrigeration, and Air-Conditioning Engineers (ASHRAE): 1-800-527-4723 or (404) 636-8400; [www.ashrae.org](http://www.ashrae.org)
- American Society of Mechanical Engineers International (ASME): 1-800-THE-ASME; [www.asme.org](http://www.asme.org)
- American Solar Energy Society (ASES): (303) 443-3130; [www.ases.org](http://www.ases.org)
- Association of Energy Engineers (AEE): (770) 447-5083; [www.aeecenter.org](http://www.aeecenter.org)
- Association of Energy Service Professionals International (AESPI): (561) 432-8000; [www.aespi.org](http://www.aespi.org)
- Center for Renewable Energy and Sustainable Technologies (CREST): (202) 293-2898; <http://solstice.crest.org/index.shtml>
- Coalition on the Environment and Jewish Life: [www.coejl.org](http://www.coejl.org)
- Electric Power Research Institute (EPRI): 1-800-313-3774; [www.epri.com](http://www.epri.com)
- Energy-Efficiency and Renewable Energy Clearinghouse (EREC): 1-800-DOE-EREC; [www.eren.doe.gov](http://www.eren.doe.gov) and [www.eren.doe.gov/EE/buildings\\_related.html](http://www.eren.doe.gov/EE/buildings_related.html)
- Energy User News: (248) 362-3700; [www.energyusernews.com](http://www.energyusernews.com)
- Episcopal Power and Light: [www.theregenerationproject.org](http://www.theregenerationproject.org)
- Evangelical Environmental Network: <http://creationcare.org/>
- Interfaith Coalition on Energy (ICE): [www.sustainable.doe.gov/success/interfaith\\_coalition.shtml](http://www.sustainable.doe.gov/success/interfaith_coalition.shtml)
- International Dark Sky Association: [www.darksky.org](http://www.darksky.org)
- Islam and Ecology: [www.crosscurrents.org/islamecology.htm](http://www.crosscurrents.org/islamecology.htm)
- Lighting Research Center: (518) 687-7100; [www.lrc.rpi.edu](http://www.lrc.rpi.edu)
- National Association of Energy Services Companies (NAESCO): (202) 822-0950; [www.naesco.org](http://www.naesco.org)
- National Council of Churches: (212) 870-2227; [www.nccusa.org/](http://www.nccusa.org/)
- National Religious Partnership for the Environment: (212) 316-7441; [www.nrpe.org/](http://www.nrpe.org/)
- National Society of Professional Engineers (NSPE): (703) 684-2800; [www.nspe.org](http://www.nspe.org)
- Religions of the World and Ecology: Discovering the Common Ground: [www.crlc.org/commonground.html](http://www.crlc.org/commonground.html)
- United States Catholic Conference: [www.nccbuscc.org](http://www.nccbuscc.org)

# Making A Good Building Even Better

**E**NERGY STAR partners have reduced their buildings' energy costs by an average of about 30 percent, and upgrades at these sites continue.

Even if your building is already relatively energy efficient, nearly every building can reduce its energy costs by at least 10 percent with measures that pay for themselves in less than 3 years. Energy cost reduction of 50 percent or more will be economically achievable at some sites.

The best way to measure your energy use is by calculating it per square foot and comparing it with other buildings that have the same type of use (office, education, health care, lodging, etc.) that you do. Look at the worksheet and charts on pages 12 and 13. The charts show the national average of typical annual energy use by building type and by climate zone.

Keep in mind that the values on pages 12 and 13 are averages. An "average" congregational building typically will have opportunities to lower its bills by 30 percent. A facility using more than the average amount of electricity and fuel may have even better opportunities.

Even a facility significantly below the average usually can find potential savings through measures that emphasize the newest technologies (such as ENERGY STAR labeled office equipment). To find the best upgrades for your building and equipment, identify the area of your highest energy use. The best place to start is to review your electric, natural gas, fuel oil, and other energy bills for the past year. Select your highest bill. Is it highest in summer? This could indicate high air-conditioning costs. Is it highest in winter? If you currently have electric resistance heat, you may save money by converting to natural gas or fuel oil. Are your electric bills higher in spring and fall than in summer and winter? Simple modifications to your heating and cooling systems may provide excellent savings. You may discover that your peak electricity use occurs during a time of year when rates are higher.

In addition, your electric bills may have a demand charge component, which is a charge based on your peak rate of electricity use. These factors make it especially important to select energy-efficiency upgrades that will lower your energy use when the utility's rates are higher or when your facility's demand is at its peak.

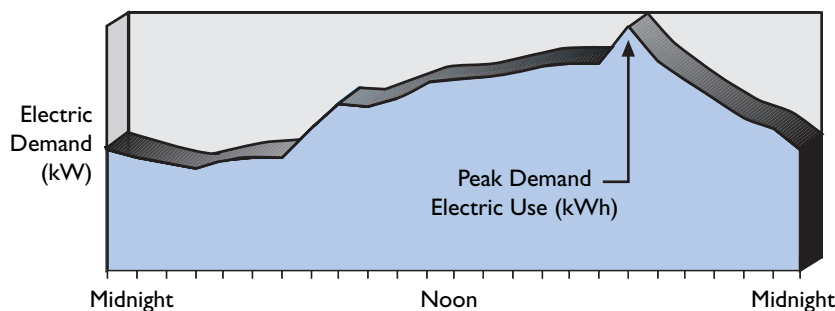

If you are charged a "demand charge" on your electric bill, you pay a fee based on your peak rate of electricity consumption. Lowering your peak rate of usage can save big.



## Using Utility Bills To Forecast Upgrade Costs

You can use your current utility bills to estimate the total cost of upgrades that may be cost effective. EPA's experience with energy-efficiency upgrades has shown upgrade savings to be between 10 and 50 percent of existing utility bills. Because the typical upgrade costs three times what it saves in one year, you can anticipate an upgrade budget of roughly 100 to 150 percent of your total annual utility bills.

For example, if your annual utility bill is \$24,000 (for all fuels), it may be cost effective to anticipate spending \$24,000 to \$36,000 on upgrading your equipment. (You can find information on financing these upgrades starting on page 27.) This budget can be a good reality check once you start getting prices from suppliers and contractors. Of course, you may encounter savings higher or lower than this depending on your facility.

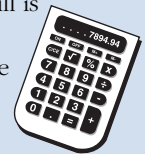

## Average Energy Use And Costs Throughout The United States

### Calculate Your Total Energy Intensity

(for online version go to [www.epa.gov/congregations](http://www.epa.gov/congregations))

1. Collect one year of bills for each energy type and multiply by these conversion factors:

Annual kWh of electricity x 3.4 \_\_\_\_\_

Annual therms or ccf of natural gas x 100 \_\_\_\_\_

Annual gallons of #2 fuel oil (diesel fuel) x 140 \_\_\_\_\_

Annual gallons of #6 fuel oil x 150 \_\_\_\_\_

Annual Mlb. of purchased steam x 1,040 \_\_\_\_\_

Annual gallons of propane x 91 or \_\_\_\_\_

Annual pounds of propane x 22 \_\_\_\_\_

Total (A) \_\_\_\_\_ kBtu/year

(B) \_\_\_\_\_ square feet

2. Write down the size of your facility, in square feet

3. Calculate your total energy intensity by dividing (A) by (B), and write this number on line (C). (C) \_\_\_\_\_ kBtu/sq.ft./year

4. Find the climate map with your location shaded. Then find the average energy use and costs for similar buildings on the adjacent table and compare them with your energy use from line (C). How do you rate?

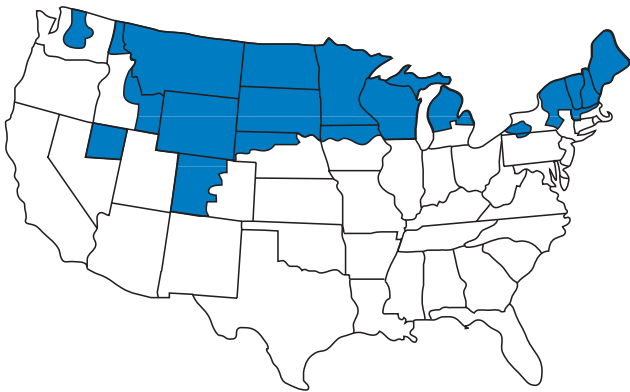

<b>U.S. Climate Zone 1</b>		
<b>Building Type</b>	<b>Annual Energy Use (kBtu/sq.ft.)</b>	<b>Annual Energy Cost (\$/sq.ft.)</b>
Education	77	\$0.93
Food service	155	\$2.32
Health care (inpatient)	270	\$2.65
Health care (outpatient)	118	\$1.33
Lodging	133	\$1.42
Office	93	\$1.46
Public assembly	66	\$0.95
<b>Religious worship</b>	<b>53</b>	<b>\$0.48</b>
Restaurant	250	\$3.99
Retail	77	\$0.99
Warehouse (non-refrig.)	59	\$1.09
Warehouse (refrigerated)	65	\$1.45

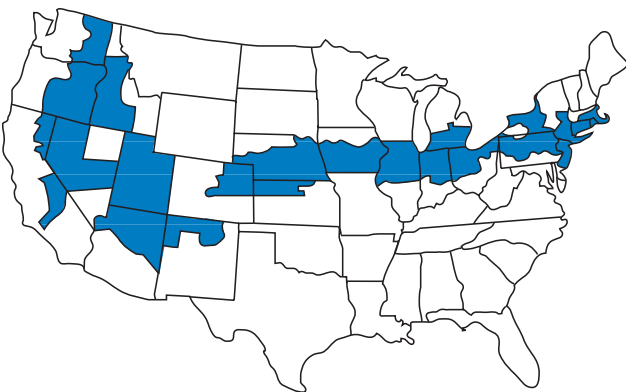

<b>U.S. Climate Zone 2</b>		
<b>Building Type</b>	<b>Annual Energy Use (kBtu/sq.ft.)</b>	<b>Annual Energy Cost (\$/sq.ft.)</b>
Education	88	\$1.08
Food service	169	\$2.19
Health care (inpatient)	269	\$2.63
Health care (outpatient)	84	\$1.25
Lodging	92	\$1.54
Office	95	\$1.49
Public assembly	77	\$1.26
<b>Religious worship</b>	<b>61</b>	<b>\$0.68</b>
Restaurant	250	\$3.99
Retail	87	\$1.21
Warehouse (non-refrig.)	64	\$0.80
Warehouse (refrigerated)	65	\$1.45

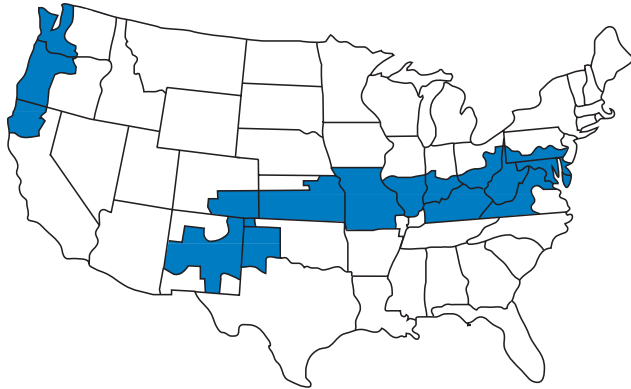

U.S. Climate Zone 3		
Building Type	Annual Energy Use (kBtu/sq.ft.)	Annual Energy Cost (\$/sq.ft.)
Education	69	\$0.99
Food service	213	\$2.73
Health care (inpatient)	204	\$2.35
Health care (outpatient)	80	\$1.30
Lodging	96	\$1.86
Office	80	\$1.59
Public assembly	66	\$1.19
<b>Religious worship</b>	<b>35</b>	<b>\$0.45</b>
Restaurant	226	\$4.16
Retail	64	\$1.25
Warehouse (non-refrig.)	51	\$0.93
Warehouse (refrigerated)	65	\$1.47

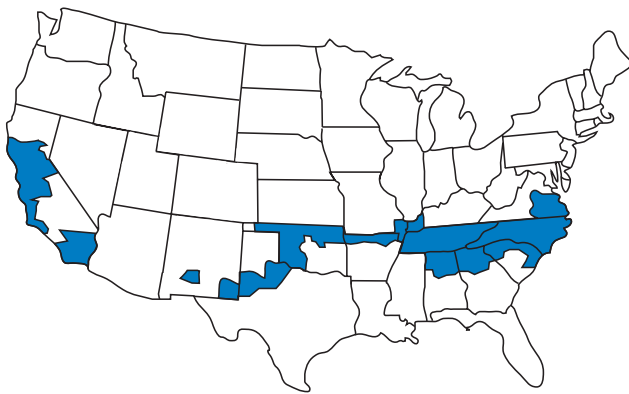

U.S. Climate Zone 4		
Building Type	Annual Energy Use (kBtu/sq.ft.)	Annual Energy Cost (\$/sq.ft.)
Education	66	\$1.17
Food service	232	\$2.49
Health care (inpatient)	227	\$2.89
Health care (outpatient)	74	\$1.36
Lodging	115	\$1.65
Office	72	\$1.54
Public assembly	72	\$1.32
<b>Religious worship</b>	<b>38</b>	<b>\$0.59</b>
Restaurant	134	\$3.03
Retail	68	\$1.36
Warehouse (non-refrig.)	36	\$0.83
Warehouse (refrigerated)	96	\$2.02



U.S. Climate Zone 5		
Building Type	Annual Energy Use (kBtu/sq.ft.)	Annual Energy Cost (\$/sq.ft.)
Education	56	\$1.11
Food service	195	\$2.89
Health care (inpatient)	202	\$2.76
Health care (outpatient)	100	\$1.67
Lodging	102	\$1.62
Office	68	\$1.55
Public assembly	54	\$1.17
<b>Religious worship</b>	<b>34</b>	<b>\$0.59</b>
Restaurant	161	\$3.20
Retail	56	\$1.26
Warehouse (non-refrig.)	33	\$0.77
Warehouse (refrigerated)	55	\$1.17

## Success Story

### A Congregation That Cares

Congregation Beth El-Keser Israel (BEKI)—a traditional egalitarian participatory Conservative synagogue community in New Haven, CT—honors energy and environmental conservation as part of its faith. BEKI has just begun to scratch the surface of its energy-efficiency potential and is focused on conserving, preserving, and saving for many years to come. The temple's active participation in conservation issues makes the future a little brighter not only for its several hundred members, but for people of all faiths everywhere.

#### A Guiding Light

BEKI has Rabbi Jon-Jay Tilsen to thank for its energy-efficiency rebirth. Tilsen currently is overseeing BEKI's energy-efficiency projects as well as planning for the temple's future.

BEKI already has begun with upgrades to its exterior and interior lighting, windows, and air conditioning. Replacing old incandescent lights with new, high-output metal halides in outdoor applications and efficient T-8 fluorescent lights with electronic ballasts in interior offices and hallways was a priority. BEKI replaced a large number of broken and cracked windows to eliminate drafts and upgraded the inefficient 20-year-old air-conditioning units with new energy-efficient models. These efforts already have resulted in \$600 in annual savings and the prevention of 11,000 pounds of CO<sub>2</sub> from entering the air each year—a promising start with more to come.

#### Blending Religious Convictions With Technology

Religious beliefs do not permit many Jewish individuals to adjust mechanical or electrical devices (such as lighting and heating) on the

Sabbath (sunset Friday through sunset Saturday) and during religious festivals (13 days each year). Therefore, the use of photocells and timers that can be set before the beginning of Sabbath or festivals helps BEKI members make sure that lights and systems are on only when needed, while strictly observing their faith. Otherwise, the temple would have to let all building systems run continuously during the Sabbath and festivals, which would be an unintentional waste of resources. What a great example of using technology efficiently to maintain an age-old tradition!

#### A Bright Future Awaits

By selecting an architect to design a master plan for energy-efficient building improvements, BEKI is well on its way to a bright and efficient future. Planned facility upgrades include replacing an archaic central cooling system, upgrading all remaining incandescent lights with new, efficient fluorescents, converting an old, single-zone oil heating unit to a system with several smaller, more efficient, multizone units, and adding staged improvements to windows, appliances, ovens, and hot-water heaters.

#### A Modest Proposal

Energy consumption may be costing your congregation and our environment more than it should.

As Congregation BEKI has demonstrated, your congregation can choose from many energy-efficient options available. **The savings generated by energy efficiency is measured not only in financial gain, but in something even more important than money: the protection of the Earth, on which we all live and breathe.**

# Selecting A Contractor



## Resources Through ENERGY STAR For Congregations

**S**electing contractors and other professionals who are ENERGY STAR product and service providers will help ensure that your job will be performed in accordance with the latest energy-efficiency technologies. A list of participants can be obtained by calling the EPA ENERGY STAR hotline at 1-888-STAR-YES, or see the Energy Services and Products Directory (<http://yosemite.epa.gov/appd/asap/home.nsf>) and find ENERGY STAR labeled products and retailers online through the ENERGY STAR Web site ([www.epa.gov/energystar.html](http://www.epa.gov/energystar.html)). At these Web sites you can search for ENERGY STAR product and service providers by type of service, specific product, or location. The directory even contains direct links to many product and service providers' Web sites.

EPA sponsors a national toll-free hotline for ENERGY STAR for Congregations Partners to learn how to get upgrades done or to network and exchange information on what works. Just call 1-888-STAR-YES and ask for technical support.

## Using Utility Bills To Forecast Upgrade Costs

You can use your current bills to estimate the return on investment of cost-effective upgrades. EPA's experience with energy-efficiency upgrades has shown savings to be between 10 and 50 percent of existing utility bills. Because the typical upgrade costs three times what it saves in one year, you can anticipate an upgrade budget of roughly 100 to 150 percent of your total annual utility bills.

For example, if your annual utility bill is \$24,000 (for all fuels), it may be cost-effective to anticipate spending \$24,000 to \$36,000 on upgrading your equipment. (You can find information on financing these upgrades starting on page 27.) This budget can be a good reality check once you start getting prices from suppliers and contractors. Of course, you may encounter savings higher or lower than this depending on your facility.

Look in the Yellow Pages of your phone book under Engineering Consultants (or similar titles) or call 1-888-STAR-YES for the name of your nearest ENERGY STAR product and service provider. EPA sponsors national workshops for ENERGY STAR for congregation partners to learn how to get upgrades done or to network and exchange information on what works.

A critical step in the success of a building upgrade project is the evaluation of proposals. Detailed coordination during the project minimizes the inconvenience to your congregation and allows the contractor to perform a profitable, high-quality installation.

## Solicit Competitive Bids

For larger projects, an ENERGY STAR partner should issue a request for proposals (RFP) to get competitive bids based on the same scope of work. Although this may seem like a lengthy process, it could save you a lot of money on design and construction costs in the long run. For smaller projects, it may not be cost-effective to go through the RFP procedure. The break-even point for issuing an RFP

---

*EPA sponsors a national toll-free hotline for ENERGY STAR for congregation partners to learn how to get upgrades done or to network and exchange information on what works. Just call 1-888-STAR-YES and ask for technical support.*

---

*A critical step in the success of a building upgrade project is the evaluation of proposals.*

depends on project size and complexity and whether in-house personnel are sufficiently skilled to prepare the RFP document. At the very least, you should get multiple bids on any large job.

The RFP structure depends on how much background work already has been completed on the project. If no preliminary work has been done on project development or design, a congregation will need a more complete menu of services than might otherwise be the case. This RFP would invite interested parties to visit the site and conduct initial surveys of the facilities to identify potential projects. Based on these initial surveys, contractors may submit details of projects they have identified, including estimates of energy savings and cost savings and a description of other benefits.

If a survey identifies energy savings opportunities, all potential bidders can be provided with a copy. Contractors can then base their proposals on the information provided or propose modified or alternative solutions that are more cost-effective.

If a design has been completed on a specific energy measure, a congregation can provide potential bidders with a set of design drawings from which they can develop their installation cost proposal.

Evaluation of proposals is a critical step in the success of a building upgrade project. Comparing proposals—especially those that contain different energy-saving strategies or specified equipment—requires a basic knowledge of the technologies involved. If this expertise is not available within a congregation, an outside source such as an ENERGY STAR product and service provider or an engineering consultant should be part of the selection process.

The following guidelines will assist you in selecting the best contractors for

your job regardless of whether you issue an RFP.

## **Interview Prospective Contractors**

Contractors will be eager to discuss their capabilities and experience with you. Ask if they have worked on similar projects. Discuss the type of working relationship they like to establish. Get information on the complete scope of services available, including project management, consulting, verifying others' work, operations and maintenance, arranging for financing, filing utility rebate documentation, and so on. Request information on the number and the experience of engineers who will be assigned to your project and check to see if they are affiliated with the relevant professional societies. Ask contractors if they have received any awards or had their work featured in magazines or journals.

## **Check References**

Obtain the phone numbers of three congregations or businesses where the contractors have performed similar work. Call them and ask if they are pleased with the contractors' work and how the contractors responded to any problems that occurred over the course of the project. Local contractors that have been in business in your community for a long time have a stake in their good reputation.

## **Manage Contractors**

Detailed coordination while the project is underway will minimize the inconvenience to your staff while allowing the contractor to perform a profitable, high-quality installation. Regular meetings with your contractor and other relevant personnel are essential. Well-defined project stages combined with interim payments will serve as a

mechanism of dialogue during the project. For example, 10 percent of the project cost can be due at presentation and acceptance of design drawings, 70 percent can be due in stages as the work progresses, and the final 20 percent can be due after performance verification and staff training.

## Settle Difficulties

Don't pay your final bill until you're satisfied with the work, and remember that as a consumer, you have every right to satisfactory service. For big air-

conditioning jobs, a revisit to tune up the system is not unusual. Reputable contractors often will make the extra effort to ensure that you're a satisfied customer.

In the unlikely event that serious problems do arise, consider binding arbitration. Binding arbitration has become common among the building trades because it offers fast resolution with little of the expense or unresponsiveness of the legal system. We recommend that you consider specifically citing the use of binding arbitration in your contracts.

---

*Detailed coordination during the project minimizes the inconvenience to your congregation's staff and members and allows the contractor to perform a profitable, high-quality installation.*

# Benefiting From Energy Savings As A Tenant



**W**hile most congregations own the space in which they worship, there are those that do not. This section describes strategies for reducing energy and rent costs for congregations that are among those that do not own their own space. Whether the cost of utilities is billed directly to you by the utility companies or is included in the rent, all tenants ultimately pay to keep buildings comfortable and well lit.

Tenants are often disinclined to invest in the building itself, however, because they don't own the premises.

## If You Pay Your Utilities Directly

If you pay your utility bills directly, any upgrade will be worthwhile if it meets your investment criteria and pays for itself before you expect to move. Because upgrades typically increase the value of leased space, you may be able to get your landlord to subsidize the upgrade cost or decrease your monthly rent. The latter possibility makes a good energy-efficiency investment even better, and you may end up with a better deal than if you owned your space.

In some leasing arrangements in which the tenant pays the utility bills, the landlord marks up the cost of utilities with a handling fee of approximately 10 percent. If so, your incentive to reduce energy costs is greater than if you own the building because you can save even more.

## Success Story

### Congregation Members May Have A Home Office

A consulting engineer in Bethesda, MD, used a rented house as her office. When she first moved in, the house was cold and drafty and had exorbitant utility bills. To improve working conditions and save energy, she negotiated an arrangement with her landlord. The consultant and her husband purchased and installed attic insulation, new double-pane windows, top-quality indoor shades, new doors, and a programmable thermostat. The landlord reimbursed them for materials and also paid for their labor at 50 percent of the market rate. The improvements saved the consultant about \$50 per month during the summer and winter months and greatly increased comfort. Furthermore, the landlord reduced the consultant's rent by 20 percent, or \$200 per month, for one year after the renovations to compensate her for her efforts. The landlord benefited as well. He had a stable lease, and once the consultant did move out, he sold the house in only 3 weeks and made a profit of \$75,000. An estimated \$10,000 of that profit was due to the recent renovations.

	Costs	Benefits
<b>The Tenant</b>	<ul style="list-style-type: none"> <li>• Time to install upgrades</li> </ul>	<ul style="list-style-type: none"> <li>• More comfort</li> <li>• \$400/year decrease in gas and electric bills</li> <li>• \$2,400/year less in rent</li> </ul>
<b>The Landlord</b>	<ul style="list-style-type: none"> <li>• \$3,115 for materials</li> <li>• \$840 for labor</li> <li>• \$2,400 rent reduction</li> </ul>	<ul style="list-style-type: none"> <li>• \$3,115 in tax deductions</li> <li>• \$840 in free labor</li> <li>• \$10,000 in capital appreciation</li> </ul>

## If Utility Costs Are Included In Your Lease

Your congregation may not own your building. If you don't pay your own utility bills, ask your landlord if you can get a \$100 monthly rent reduction if you install new lights that use \$90 less energy per month and increase the property's market value. Your landlord just might say yes. Alternatively, your landlord might pay for the total cost of upgrade projects if she or he believes that the upgrades will extend the time you remain in the space. Remind the landlord that capital improvements often are tax deductible.

## Focus On No-Cost Or Low-Cost Opportunities

Even given the rationale above, typical tenants will not be interested in investing significantly in new windows for a building owned by someone else (unless the investment is part of a larger marketing "image makeover"). Tenants often are best served

by focusing on measures that require little capital and will help increase comfort. These measures can save tenants a surprising amount of money and are ideal for congregations that rent their facilities.

## Focus On Savings You Can Take With You

ENERGY STAR labeled office equipment



represents a lasting investment for your congregation. If you buy an ENERGY STAR labeled computer, fax machine, copier, or printer, the equipment stays with you even if you move, so your savings don't depend on the length of your lease.

## Refer Your Landlord To Us

Landlords also can benefit from your participation in ENERGY STAR for congregations or their own participation in the appropriate ENERGY STAR program. Have your landlord call the ENERGY STAR toll-free hotline at 1-888-STAR-YES to discuss materials and services specifically designed for property managers.

---

### No-Cost Options

- Turn up or turn back thermostats during unoccupied times (consider installing a programmable thermostat; see page 72)
- Turn off lights and office equipment at night and over the weekend
- Take advantage of daylight
- Use e-mail instead of paper memos
- Disconnect unnecessary equipment such as unused freezers, water heaters, and transformers

### Low-Cost Options

- Caulk and weather-strip windows and doors
  - Replace light bulbs with more efficient ones
  - Install occupancy sensors in areas such as conference rooms and storage rooms
  - Install timers on electric water heaters or other equipment
  - Install awnings or shades to keep out the summer sun and lower air-conditioning costs
  - Fix leaking faucets, showerheads, pipes, or toilets
-

# Verifying Savings



**Y**ou can't see energy, so it can be hard to tell if an upgrade is a success. As an ENERGY STAR congregational partner, you will want to make sure that the money you invest in implementing energy-efficiency measures provides the anticipated savings on your utility bills. This section describes the features of successful programs and highlights principles you can apply to quantify savings.

## Compare Before And After Utility Bills

Bill comparison provides you with a way to quantify your savings after implementing energy-efficiency measures. Because so many different factors affect bills, this approach is most revealing when you have implemented major projects that should save you more than 10 percent. Simply add up your energy bills for the year prior to implementation of the measures and for the year after project completion. Subtract the 12 months of "after" from the 12 months of "before" and you will have your gross cost savings.

You will need to adjust the gross savings depending on differences in behavior and changes in energy prices and weather during the 2 years. For example, if your facilities or hours expanded 20 percent over the course of the 2 years, then it is likely that your energy use increased as well. Take this into consideration. Many utility bills will include a statement about the number of "heating degree days" that occurred during the billing period. Bill analysis should take into

account yearly variations in weather. For example, during a very mild winter, your heating system might not be running at full capacity; therefore, energy savings associated with the heating system might not be obvious.

## Spot Metering

Spot metering is particularly applicable for lighting upgrades. Ask your lighting contractor to turn on all the old lights that are to be replaced, then measure the current leaving the circuit breaker and leading to the fixtures for at least one circuit. After the upgrade is complete, measure the current for the same circuit and perform the following calculations:

1. Subtract the lower post-upgrade current from the higher pre-upgrade current.

---

*Bill comparison lets you quantify your savings after you implement energy-efficient measures.*

---

## Verifying Savings: The Keys To A Successful Program

Your chances of truly lowering your costs will increase if you:

- Focus your upgrade projects on the areas of highest energy use at the facility
  - Focus on proven energy-efficiency technologies
  - Meter before and after the job is complete
  - "Commission" the project; that is, inspect and verify proper installation and operation
  - Find ENERGY STAR product and service providers located in the ENERGY STAR directory
  - Use internal or hired staff who have a track record of success
  - Hire a top-quality contractor
-

2. Multiply the change in current by the voltage to determine watts saved on the circuit.
3. Divide watts saved by the number of upgraded fixtures to determine watts saved per fixture.
4. Compare the watts saved per fixture to your expectations and the supplier's quote.

Insist that the current measurement be done in your presence. This exercise will take less than 10 minutes and will give you confidence in the project's success.

### Extended Metering

Although installing additional meters to measure energy consumption directly usually is beyond the scope of energy-efficiency projects, innovative strategies may provide some of this information. For example, if you install timers on some equipment to facilitate scheduled maintenance, these timers can be recorded to verify the performance of energy savings measures that result in

reduced equipment operation hours. Some programmable thermostats are equipped with simple functions that estimate the hours of heating or cooling use; these could be used to test the effectiveness of insulation measures. Likewise, many energy management systems (EMS) contain sophisticated features for analysis of building energy use that can be used to verify predicted savings.

### Benefits Beyond The Meter

Measuring the financial performance of your investment in energy-efficiency technologies is important to ensure the project's soundness. However, the most significant results will be felt in your congregation as you take on stewardship of the earth. Members will be proud to belong to a congregation that cares about the world and excited by your efforts, and may even take on similar efforts in their homes, businesses, and schools, increasing the benefit to the environment.

# ENERGY STAR Support For Congregations



**E**NERGY STAR for congregations is voluntary and easy, and it will help you save money. We're here to help congregations apply cost-effective and proven energy-efficiency technologies. Congregations like yours not only will save money, they also will help lay the foundation for a cleaner planet for future generations.

The family of ENERGY STAR—encompassing commercial and industrial buildings, homes, office equipment, appliances, and many other areas—aims to reduce pollution and protect our environment through application of energy-efficiency technologies. Making homes, businesses, and industry more energy efficient reduces the amount of pollution released into the atmosphere because utilities don't need to generate as much electricity. That means they aren't burning as much fossil fuel, and that, in turn, means they aren't releasing pollutants into the atmosphere.

## What Happens If You Leave ENERGY STAR?

Your congregation will continue to pay more than necessary for energy and your pollution prevention contribution and your financial and natural resource stewardship opportunities will be missed.

Otherwise, ENERGY STAR is voluntary and there are no penalties. EPA wants to help you succeed in saving money and preventing pollution, and as long as you are willing, we will work with you to make it happen. Your congregation can reap the rewards of lower costs; more comfortable, higher quality facilities; and the knowledge that you are helping protect the environment.

## Pollution Prevented Through Energy Savings

For each kilowatt-hour (kWh) that you save through the application of energy-efficiency technologies, you reduce the emissions of carbon dioxide (CO<sub>2</sub>), sulfur dioxide (SO<sub>2</sub>), and nitrogen oxides (NO<sub>x</sub>) by the amounts shown in your region (see page 24). Excessive carbon dioxide emission is a primary cause of global climate change, sulfur dioxide is a key constituent of acid rain, and nitrogen oxides are responsible for smog. You will save money and help the environment at the same time, and your community will appreciate your efforts.

Pollution prevention efforts vary around the country because electric utilities use a variety of fuels and various types of power plants to generate your electricity. In the Pacific Northwest, where hydroelectric dams are prevalent, emissions rates are comparatively low. The environmental impact can be just as high, however, because of salmon migration disruption and other issues. In other regions the mix of "clean" coal, "dirty" coal, natural gas, nuclear power, and renewable sources such as wind turbine farms affects emission rates.

An exciting prospect for the deregulated future is the marketing of "green pricing" by electric utilities. Already pilot-tested in parts of California and Pennsylvania, green pricing allows customers to specify that they want their electricity to be generated from renewable sources (solar or wind) or from particularly clean-burning power plants. In exchange the customer pays a slightly higher cost for this higher

*EPA wants to help you succeed in saving money and preventing pollution, and as long as you are willing, we'll help you make it happen.*

### ENERGY STAR And Green Lights Program Results

#### Through December 1998

- 19 billion pounds of pollution prevented
- \$800 million in energy savings

#### Equivalent To

- Taking 1 million cars off the road
- or
- Planting 2 million acres of trees

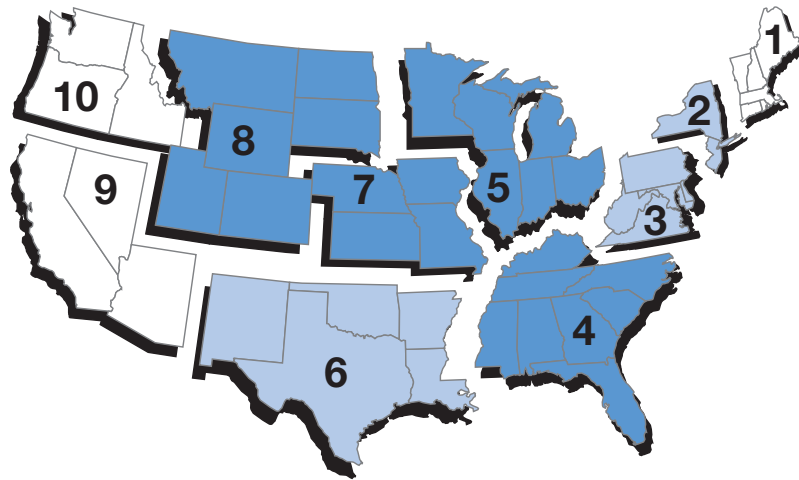

**Map Of Pollution Prevented Per 1,000 kWh Saved**

EPA Pollution Emission Region	Carbon Dioxide (CO <sub>2</sub> ) Pounds/Year	Sulfur Dioxide (SO <sub>2</sub> ) Pounds/Year	Nitrogen Oxides (NO <sub>x</sub> ) Pounds/Year
1	1,100	8.8	3.1
2	1,200	7.5	2.9
3	1,600	7.1	5.5
4	1,500	15.2	5.5
5	1,800	22.9	7.7
6	1,700	4.9	5.5
7	2,000	7.7	8.6
8	2,200	7.3	7.1
9	1,000	2.4	3.3
10	100	1.1	0.7

grade of power. Look for green power in the future. Information can be found at [www.epa.gov/congregations](http://www.epa.gov/congregations).

### Congregant Home Offices

The growth of the Internet, telecommuting, and decentralized sales forces have triggered a huge increase in the number of home offices. Some of your congregation members may have offices or businesses in their homes and would like to consider the benefits of ENERGY STAR labeled office equipment and our residential support services. ENERGY STAR labeled homes use 30 percent less energy than required by the national Model Energy Code and have other health and comfort advantages. (See page 19 for an example of upgrades made to an existing home office.) Call

1-888-STAR-YES or visit the Web site at [www.epa.gov/smallbiz](http://www.epa.gov/smallbiz) and click on “home office” for more information.

### Additional Resources

- <http://yosemite.epa.gov/appd/eshomes/eshaware.nsf> (new homes)
- [www.eren.doe.gov/consumerinfo/energy\\_savers/](http://www.eren.doe.gov/consumerinfo/energy_savers/)
- [www.ase.org/checkup/home/](http://www.ase.org/checkup/home/)
- [www.eren.doe.gov/consumerinfo/factsheet.html](http://www.eren.doe.gov/consumerinfo/factsheet.html)
- [www.eren.doe.gov/consumerinfo/forhome.html](http://www.eren.doe.gov/consumerinfo/forhome.html)
- [www.eren.doe.gov/consumerinfo/finance.html](http://www.eren.doe.gov/consumerinfo/finance.html)



2

# Technical Support

# Financial Analysis



**E**NERGY STAR for congregations finance directory is available on-line in searchable format, with direct links to participating lenders. Alternatively, you can call the toll-free hotline at 1-888-STAR-YES to request the list for your area.

Consider a congregation with annual energy costs of \$25,000. If a comprehensive upgrade program could reduce energy use by 30 percent, this congregation could save \$7,500 per year. Assume that the cost of implementing these measures results in a 3-year simple payback, which is typical. In delaying the upgrade, this congregation is forfeiting a low-risk investment opportunity at 27-percent interest.

## Indirect Financial Benefits

In addition, the total return on your project includes these additional financial components that are quite real, if indirect:

**Increased Member And Staff Comfort.** Building upgrades will improve your facility's appearance and help your members be comfortable.

**Operations And Maintenance Savings.** Many energy-efficiency technologies significantly reduce your operations and maintenance requirements, saving money and staff time.

**Enhanced Employee Productivity.** Due to enhanced comfort and improved lighting conditions, staff productivity may increase.

### Protection From Energy Inflation.

By performing energy-saving upgrades, you replace part of the variable monthly expense of your energy bills with fixed-cost capital improvements. Lower energy use always results in lower costs—more so if energy prices rise.

**Educational Benefits.** Your participation in ENERGY STAR for congregations communicates your commitment to environmental stewardship. This message will help members understand

*Savings from your energy bills may help fund your congregation's other projects.*

## What Is Energy Worth To You?

The following table may be of interest to members of your congregation who operate a business-type facility (e.g., a bookstore).

1. You've got a great energy savings idea. How much will it save per year? (A) \$ \_\_\_\_
2. Enter your pretax profit as a percentage of sales: (B) \_\_\_\_ percent
3. Divide A by B: (C) \_\_\_\_

Line (C) shows your equivalent annual increase in sales once your savings have paid for the cost of the measure. The table below will help you quickly look up the equivalent sales amount.

**Equivalent Annual Increase In Sales**

Annual Cost Savings For The Measure	Profit As A Percentage Of Sales			
	2%	5%	10%	20%
\$10	\$500	\$200	\$100	\$50
\$100	\$5,000	\$2,000	\$1,000	\$500
\$1,000	\$50,000	\$20,000	\$10,000	\$5,000
\$10,000	\$500,000	\$200,000	\$100,000	\$50,000
\$100,000	\$5,000,000	\$2,000,000	\$1,000,000	\$500,000

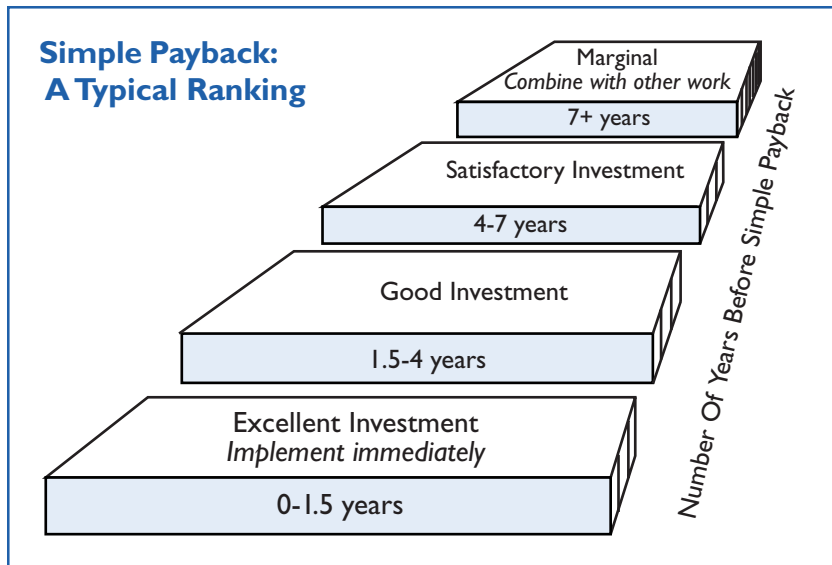

*Simple payback is the number of years it takes to recover the cost of the energy upgrade from the energy savings (see the chart on page 46 or use the online calculator located at [www.epa.gov/congregations](http://www.epa.gov/congregations)).*

what they can do in their own homes, businesses, and places of employment.

Your exact mix of indirect benefits will vary by building type and upgrades performed. For many projects, these indirect benefits will be worth several times the money you save in energy alone.

### Calculating The Worth

Once you are convinced that energy-efficiency investments make financial sense in general, you still have to evaluate individual upgrades to decide which ones to pursue. The two most common evaluation tools are simple payback and internal rate of return (IRR).

**Simple Payback.** Simple payback is the number of years it takes to recover the cost of the energy upgrade from the energy savings. A simple payback of less than 4 years indicates a worth-

while project. Measures with simple payback times of less than 1.5 years are excellent opportunities and should be implemented immediately.

### Example Of A Simple Payback

**Calculation:** Your utility gives you a free energy assessment and tells you that if you replace 20, 100-watt incandescent bulbs used 24 hours a day in your stairways with 30-watt compact fluorescent bulbs, you'll save \$980 per year. The upgrade will cost you \$400.

Your simple payback is  $\$400 \div \$980 = 0.4$  year, or just under 5 months. The only significant shortcoming of the simple payback concept is that it doesn't take into account the expected life of the upgrade. For example, if the compact fluorescent lamps described above lasted only as long as incandescent lamps, they would burn out in less than 3 months. Fortunately, compact fluorescent lamps last eight to 10 times longer, so you might want your analysis to take that into account.

**IRR.** Expressing an upgrade in terms of IRR helps you compare the financial results of an upgrade against other investments. (See the glossary for a definition of IRR.) To calculate IRR, you'll want to use a computer spreadsheet program or a financial calculator; you can use the table on the following page as a general reference.

You can compare the IRR you calculate with the interest rates available at banks or through other investments. A good rule of thumb is that projects with IRRs above 20 percent are excellent investments and should be implemented.

Compare Your Energy-Efficiency Investments To The Interest Rates You Can Get At A Bank									
This table will tell you the IRR if you have already calculated the simple payback.									
Simple Payback	8 years							0%	4%
	6 years						0%	7%	11%
	5 years					0%	5%	12%	15%
	4 years				0%	8%	13%	19%	21%
	3 years			0%	13%	20%	24%	29%	31%
	2.5 years			10%	22%	29%	33%	37%	38%
	2 years		0%	23%	35%	41%	45%	48%	49%
	1.5 years		22%	45%	55%	60%	63%	65%	66%
	1 year	0%	62%	84%	93%	97%	98%	100%	100%
	0.5 years	100%	173%	192%	197%	199%	200%	200%	200%
	0 years	1 year	2 years	3 years	4 years	5 years	6 years	8 years	10 years
Lifetime of new equipment or length of your planning horizon, whichever is shorter									

**Example Of IRR:** Converting a heating system from natural gas unit heaters to gas-fired radiant heaters will cost \$6,000 and save \$1,500 a year, which is a simple payback of 4 years. You can calculate the IRR for this investment as 21 percent (using a 10-year planning horizon), which makes it a very good financial option. Compare this with bank interest rates or other investments you might make to decide whether to implement this upgrade.

### Where Can I Learn More?

Call the toll-free ENERGY STAR hotline at 1-888-STAR-YES and ask for the brochures listed below:

- *Introducing Your Company's Newest Profit Center*, EPA 430-R-97-004. Congregational members' businesses can benefit from the concept that

energy upgrades are financial investments just like other business uses of capital.

- *Business Analysis for Energy-Efficiency Investments*, EPA 430-B-97-002. This brochure describes in more detail the business-analysis approach you can use to decide if a particular upgrade or set of upgrades makes sense.
- *Financing Your Energy-Efficiency Upgrade*, EPA 430-B-97-003. This brochure describes the many financial and accounting aspects of upgrade projects in great detail. Use this information to finance your projects to have the best impact on your balance sheet, cash flow, taxes, and ultimate return.

**Upgrades should generally be implemented if the IRR is above 20 percent.**

# Prioritizing Your Projects



Use the ENERGY STAR five-stage concept to help organize a strategy for putting potential upgrades on a timeline. Each stage of the program builds on the previous stages to maximize potential energy savings, minimize investment requirements, and improve comfort and profitability for your congregation.

## Stage One: Lighting

Many buildings spend half their electricity costs on lighting, so it makes sense to address lighting first to reduce your energy costs. Efficient lighting pays for itself quickly. Lighting upgrades such as installation of compact fluorescent lamps and light emitting diode (LED) exit signs are relatively simple to implement and can deliver the expected cost savings reliably. Upgrade your lighting before changing your cooling system because increasing your lighting efficiency lowers your air-conditioning requirements. Also, in the winter, some of your heat comes from your lighting, which is expensive. New lights operate much cooler than old lights; use your heating system instead. ENERGY STAR experience shows that successful lighting upgrades provide congregational partners with dramatic savings and positive reinforcement for pursuing further projects. Lighting upgrades often improve lighting quality, and enhance the appearance of your facility inside and out. For all of these reasons, we recommend you start with lighting as your first upgrade area.

## Stage Two: Building Tune-Up

Tune the energy systems in your building to optimal performance by addressing operations, maintenance, and small repairs. You can do many tune-up activities yourself, such as cleaning equipment and replacing filters. Other tune-up measures—such as adjusting your furnace or repairing malfunctioning controls—will require the services of contractors. Stage Two upgrades improve occupant comfort and indoor air quality, and the upgrades are no-cost or low-cost strategies that lay the foundation for further savings in later stages.

## Stage Three: Load Reduction

Load reduction strategies reduce the amount of heating, cooling, or electricity use through low-cost measures that are easy to implement. Reducing the amount of heated or cooled air that escapes from your building through cracks in windows or ducts will reduce your heating and cooling costs. Window films, shades, and awnings will reduce heat gain in the summer. You also can take advantage of landscaping measures such as adding trees and vines to block direct sunlight.

Take simple steps to ensure that lights and office equipment are not left on by accident and select ENERGY STAR labeled new equipment to guarantee the best future savings.

---

*Each stage of the program builds on the previous stages to maximize potential energy savings, minimize investment requirements, and improve comfort and profitability.*

### Stage Four: Heating And Cooling Distribution System

In this stage, you should evaluate the efficiency of the fans and pumps associated with the heating, ventilating, and air-conditioning (HVAC) systems in your building. Upgrades to your distribution system will save energy while improving occupant comfort.

### Stage Five: Heating And Cooling Plant

By implementing Stages One through Four, you will reduce the overall heating and cooling requirements in your facility and will be able to afford

smaller and more efficient heating and cooling units. Because replacing heating or cooling equipment requires the largest commitment of capital, we recommend that you implement these replacements last. This is the stage when all your previous hard work and commitment will pay off.

The five-stage concept is illustrated in the chart on this page.

### Where Can I Learn More?

If you would like more information on the technical aspects of the ENERGY STAR five-stage approach to building improvements, you can view the ENERGY STAR Buildings Manual at [www.epa.gov/buildings/esbhome/tools/building.html](http://www.epa.gov/buildings/esbhome/tools/building.html).

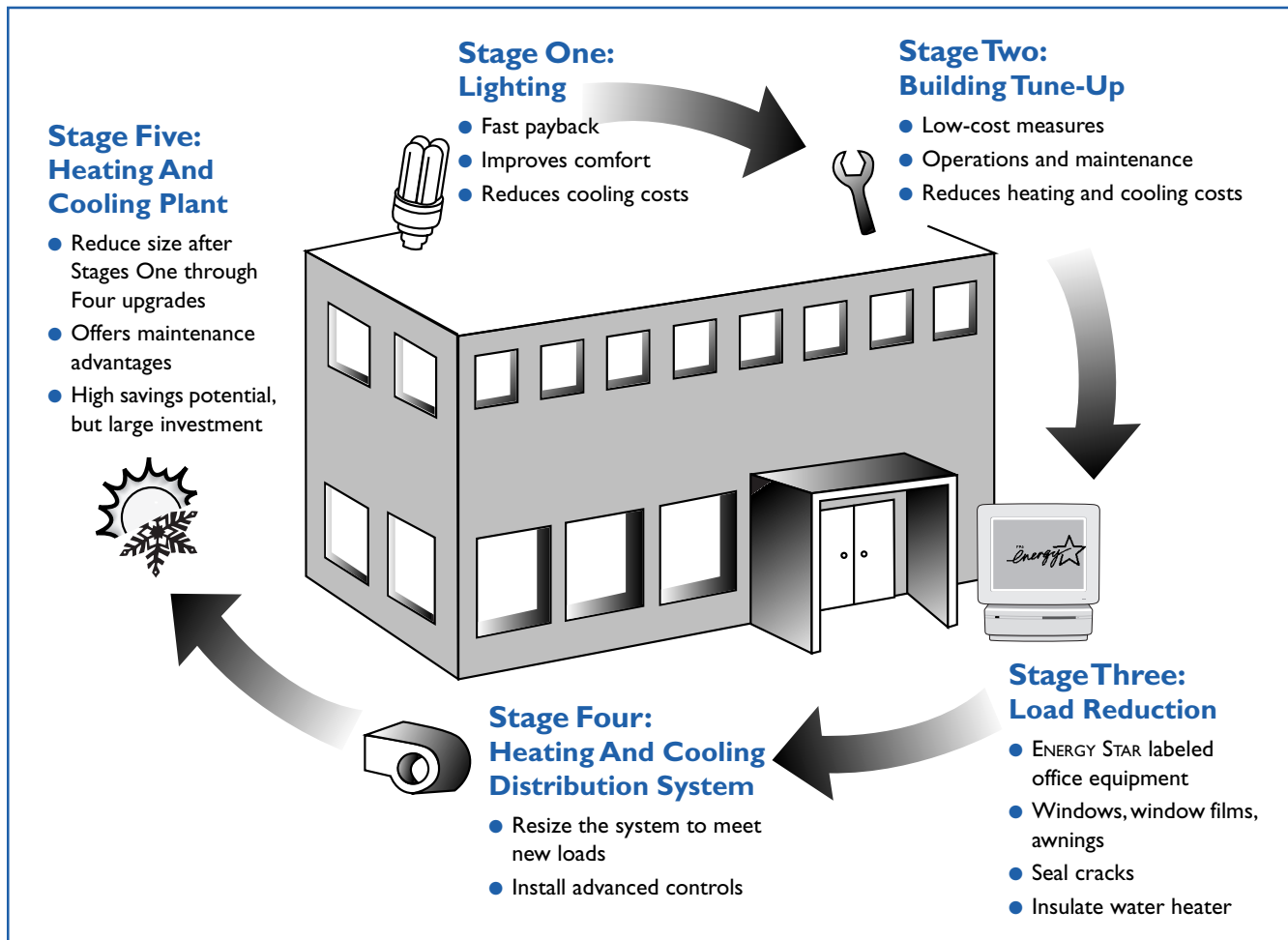

# Lighting Part I: Concepts



Approximately 75 percent of all ENERGY STAR for congregations partner upgrades are related to lighting. Because lighting upgrades are so popular, we have included this special section on lighting concepts. If you have time to read it, you can be an informed shopper when you listen to contractor upgrade proposals or find your own lighting improvement opportunities. If you don't have the time, aren't interested in the background science, or just want to focus on action, go straight to the next section, **Lighting Part II: Upgrades**. There, we introduce specific suggestions on how to improve your lighting by upgrading your fixtures.

Whether illuminating your place of worship or providing security for your parking lot, lighting is one utility that your congregation cannot do without. The amount and quality of light can significantly affect the quality of your facility and religious services. At the same time, lighting costs form a significant part of your electric bill.

Fortunately, modern technology makes it possible for many congregations to improve lighting quality while reducing costs. This section reviews how to determine the right amount of light for your building, discusses lighting quality issues such as color and glare, and introduces the different types of lighting technologies in use. Of course we must always remember that the least costly and longest-lasting light bulb is the one that is off!

## Light Levels

When everyone worked with pencils, paper, and typewriters, architects made sure that working environments had an abundance of light everywhere. Now that so many office environments require the use of computers, ideal light levels and configurations are different and often lower than in the past. Your congregation also may want softer, even dramatic lighting at times. This means you may have the opportunity to reduce your lighting costs and improve your worship and learning environments at the same time. Since removing lamps often requires nothing more than getting on a ladder and pulling out the bulbs, the cost can be negligible and you can start saving money immediately.

Although personal preferences play a large role in optimizing light levels, the Illuminating Engineering Society (IES) provides recommended light levels for different activities as shown in the graph on this page.

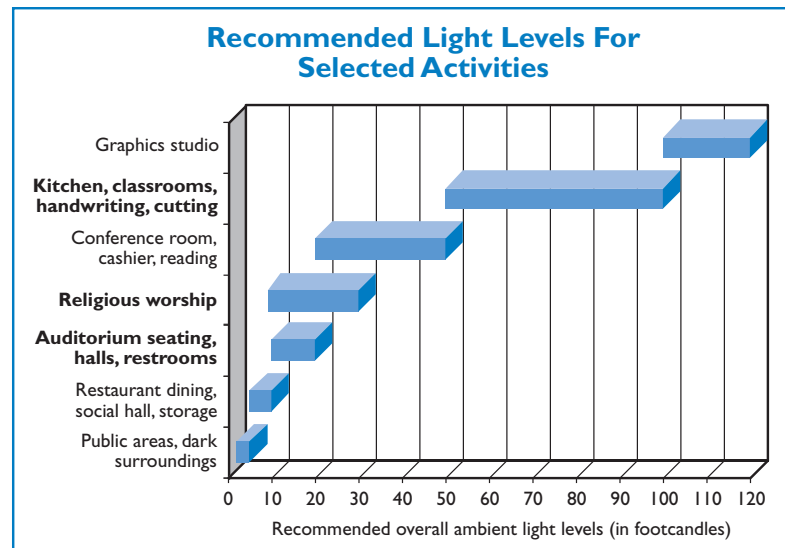

Source: Adapted from IES.

---

*Task lighting focuses extra light just where you need it and can reduce glare and eye strain.*

**Compare Your Light Levels With Recommended Levels.** To compare your lighting with recommended levels, you need to know your own existing light levels. Call your lighting contractor and ask for measurements.

Alternatively, you may want to consider buying your own light meter. They cost about \$125 and are available from lighting supply catalogs. If you buy your own meter, be sure to have a lighting expert train you before you use it. Windows, reflections, and shadows will distort your readings if you're not careful.

**Just Try It.** You don't have to bother with all those technical criteria. Remove a couple of lamps for a couple of days, and if you like the new arrangement, stick with it.

**Consider Task Lighting.** Just because you want bright light in one area doesn't mean you need the whole room lit at that level. See if you can reduce light levels in some areas and focus light only where you need it. This is called "task-ambient lighting." This type of lighting design provides a blanket of lower level, "ambient" light for orientation around large objects together with small fixtures shining on the "task." The current IES recommendations for computer use, for example, are 25 foot-candles ambient, with a task or desk light providing 75 footcandles at the work surface.

**Experiment With Daylighting.** Turn off lights near windows during daytime hours; you can do this manually with a time clock or with special "daylighting" sensors made just for this purpose. This will enhance the beauty of stained glass or other special window decorations.

## Light Quality

Isn't it frustrating to stare at your computer screen and constantly find yourself looking at the reflection of a ceiling fixture? Have you seen volunteers tape cardboard around their monitors? Does the light in the restroom make your face look pasty and less attractive than you know you looked at home this morning? It's not that your place of worship is bad for your looks. All light is not the same. These and other problems are lighting flaws that often can be overcome when you install more efficient lighting. Let's consider solutions to the problems one by one.

### **Solution 1: Task-Ambient Lighting.**

A solution that more and more interior designers recommend is a combination of background ambient and task lighting. Designers generally agree that spot lighting gives a pleasant ambience, but it can cost more to install because it requires more fixtures. Because the overall amount of light produced is lower with a mix of background and spot lighting, the arrangement uses less electricity. The extra fixture investment can pay for itself quickly in savings on your electric bills.

### **Solution 2: Upgrade Fixtures.**

Many older fluorescent fixtures use a prismatic plastic lens to scatter light around the room. This was great before the computer age because it helped to ensure that all areas were evenly lit, but lenses can create bright spots in your field of view. Now that computers are used more frequently, the preferred solution often is to use fixtures with parabolic louvers that direct light where you need it while lowering glare. If you're considering an upgrade in a room with computers, ask your designer or contractor about switching to fixtures with louvers.

**Solution 3: Improve Color.** All lamps distort color compared with true sunlight, but some lamps distort less than others. This property of lighting is called color rendition. Lamps that render close to true color have a color-rendering index (CRI) between 85 and 100. A CRI of 50 is very poor. If you upgrade to T-8 lamps from just about any type of T-12 lamps, your color rendition usually can be improved at the same time.

### Different Kinds Of Lights

Different types of lighting are available with a broad range of lighting efficiencies and varying degrees of color distortion. The efficiency of lighting (more technically called efficacy) is measured by the light output per unit of energy use. Common incandescent lamps have poor efficacies, while fluorescent lamps have much higher efficacies. See the box on this page for illustrations of the major lamp types.

**Incandescent.** Modern incandescent lamps derive from Thomas Edison's work before the turn of the century. They are inefficient and usually have short lives but produce a pleasant color rendering similar to that of natural sunlight.



**Halogen.** In the past 5 years, halogens have surged in popularity. Halogen lamps are about twice as efficient as regular incandescent lamps and have longer lives. Halogen spotlights focus light and add a lot of pleasing "sparkle." However, they are relatively expensive and cost more to operate than all other types of lamps except incandescents.



## Types Of Lighting

### Lighting Technology

	<b>Incandescent</b>
	<b>Halogen</b>
	<b>Compact Fluorescent</b>
	<b>Tubular Fluorescent</b>
	<b>High-Intensity Discharge (HID)</b>
	<b>Low-Pressure Sodium</b>

*Less than 5 percent of the electricity consumed by an incandescent lamp actually is turned into useful light.*

**Compact Fluorescent.** Compact fluorescent lamps (CFLs) are miniature versions of standard fluorescent lamps and usually are coated to make their color more similar to that of incandescent lamps. CFLs are four times as efficient as incandescents and last 10 times as long in many cases (significantly reducing the cost of changeouts, particularly in hard-to-reach areas), so they too are growing in popularity.

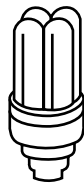

**Tubular Fluorescent.** The ubiquitous fluorescent lamps have a wide range of efficiency but in general are about four times as efficient as incandescent lamps. They are cheap, last as long as 20,000 hours,

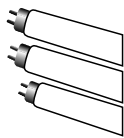

and are the staple of office lighting throughout the country.

**High-Intensity Discharge (HID).**

This category of lamp includes metal halide and high-pressure sodium. HID lamps traditionally have been used mostly in warehouses and in street lighting, but new research and development have created a market for lower power lamps for institutional environments. HID lamps offer good color, long life, and inexpensive high ceiling and security lighting.

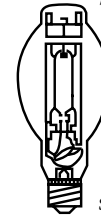

**Comparison Of Lighting Efficiency**

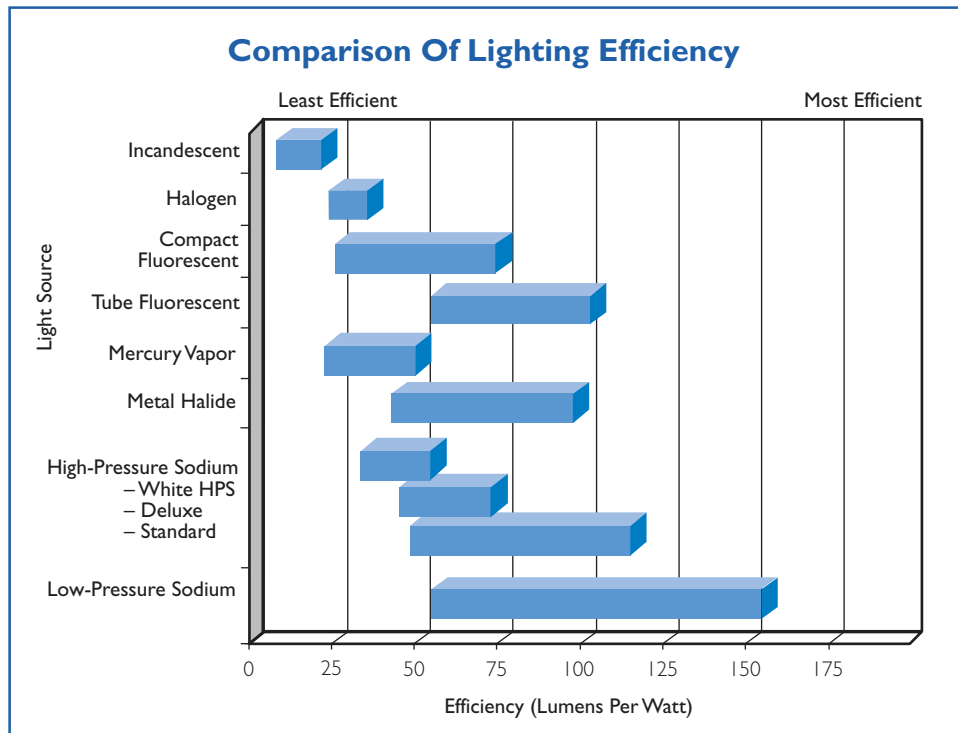

\*Note: Light sources are not necessarily interchangeable and are commonly used in different applications (see page 39). Comparison is purely based on efficiency.

## Success Story

*Because some congregations' members own or operate businesses (bookstores and so on), we are presenting the following success story.*

### Saving With The Right Light Levels

A growing firm in Portland, OR, signed a 10-year lease to occupy a 30-year-old, 50,000-sq.ft. office building. The business planned to renovate much of the space before moving in. Renovation plans for each 10-ft. by 12-ft. office in the building included replacing a pair of old, 4-lamp, 4-foot fluorescent fixtures in each office with a pair of new 4-lamp fixtures that had high-efficiency lamps and electronic ballasts.

Fortunately, the business asked its design consultant to check the light levels before signing off on the remodel drawings. The consultant checked and found that the existing light levels were about 75 footcandles (units of measure), when 50 footcandles would have been plenty. So at no cost to the tenant, the designer changed the construction specifications to 3-lamp fixtures. There were 200 offices affected by this renovation, meaning that the firm saved more than \$15,000 in 10 years by asking a simple question. That's a good deal.

---

### Better Lighting Increases Comfort

New energy-efficient lighting can do more than just reduce your utility bills. It can also add value by:

- **Improving comfort and performance for congregational staff, volunteers, and members working in the congregational office.** Energy-efficient lighting generates less localized heat than standard lighting, provides more pleasant color rendition, and helps prevent headaches by reducing the amount of flickering from the lights. Your office staff will work better when their work environment is comfortable, and better lighting will allow members to be less distracted and concentrate more on your congregational message.
  - **Improving appearances.** Better color rendition means that your house of worship will look its best. Your congregation will have better control over the ambience, feelings of comfort, and overall experience that people have in your facility.
  - **Improving your congregation's stewardship will help lead your members and their employers to consider becoming more environmentally responsible within your community.** Your members will appreciate and share your efforts to lower pollution and protect the Earth for future generations.
-

# Lighting Part II: Upgrades

**W**hat's your share of \$17 billion? That's the amount EPA estimates that United States building owners and tenants could save each year from lighting upgrades. In this section, we will help you identify lighting fixtures and controls in your facility that can be replaced while keeping your investments at a 3-year simple payback or less. Many ideas pay for themselves in less than one year. Let's get started!

If you don't have time to read this whole section, just take a quick look at the next page. It's our **Thrifty Facility Manager's High-Speed Do-It-Yourself Lighting Assessment**. Take a look at the list and call your lighting or electrical contractor if you have any of the fixtures noted. It's that easy. The rest of this section expands on the ideas in the High-Speed Lighting Assessment and explores more comprehensive upgrades as well.

## Remove Incandescent Lamps

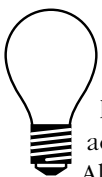

Replace these lamps with anything else. Of the electricity consumed by an incandescent lamp, less than five percent is actually turned into useful light. Although incandescent lamps are appropriate for certain low-use areas such as closets, in most instances, incandescent lamps should be replaced.

### Incandescent Lamp Replacement Options

Halogen	Highlights selected areas. Example of application: a religious symbol in your house of worship.
Compact fluorescent	Uses the same screw-in fixture. Example of application: hallway.
Fluorescent tube	For general lighting.
Metal halide	For white light in high-ceiling areas. Example of application: large public area.
High-pressure sodium	For use outside or where color doesn't matter. Example of application: outside security.
LED	For exit signs.

Note: Dimmable replacements are available from some manufacturers.

Note: "Energy saver" incandescent lamps aren't much more efficient than regular incandescent lamps. They save you money just by delivering less light. Usually, this is not the best solution.

### Replace Incandescent Lamps With Halogen Lamps.

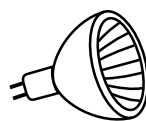

Halogen lamps are a type of incandescent lamp that is at least twice as efficient as regular incandescent lamps. They last two to four times longer than most incandescent lamps and have become increasingly popular in spotlighting and other decorative applications.

As an upgrade, the combination of better color, higher efficacy, and better cone reflectors means that many users can replace 150-watt floodlights with

## The Thrifty Facility Manager’s High-Speed Do-It-Yourself Lighting Assessment

Do you have any of the following?

<b>EXISTING LAMPS</b>	<b>USED AT LEAST</b>
Incandescent lamps	6 hrs./day
Incandescent exit signs	24 hrs./day
Four or more fluorescent or incandescent fixtures on a single circuit	4 hrs./day more than needed
Incandescent, halogen, or mercury vapor security lighting	10 hrs./day
Fluorescent lamps and ballasts more than 8 years old	10 hrs./day

If you do, here are some of your savings opportunities.

<b>OLD</b>	<b>NEW</b>	<b>SAVE (\$/yr/lamp)</b>	<b>PAYBACK IN LESS THAN</b>
Incandescent	Compact fluorescent	\$12 energy + \$3 O&M*	2 yrs.
Incandescent exit signs	LED exit signs	\$22 energy + \$11 O&M*	3 yrs.
Four or more fluorescent or incandescent fixtures on a single circuit	Occupancy sensor	\$4 to \$16 + \$4 O&M*	3 yrs.
Incandescent or mercury vapor security lighting	Metal halide (white) or sodium (light yellow)	\$40	4 yrs.
Fluorescent lamps and ballasts more than 8 years old	T-8 lamp with electronic ballasts	\$5	5 yrs.

\*Operations and maintenance

35- or 60-watt halogen lamps and still get brighter, more focused light that has better color rendition. The most popular halogen lamps cost about \$7 (compared with \$1 for incandescent lamps), but they last four times as long as incandescent lamps and save about \$25 in energy costs over their lifetime. The high operating temperatures of halogen bulbs can be a fire and personal safety hazard in some applications, so ask for advice when you first buy and install the lamps. In general, halogens are recommended for floodlight and spotlight applications only.

Halogen lamp retrofits typically pay for themselves in less than 3 years in energy savings alone if the fixtures for screw-in retrofits are used at least 2 hours a day or if fixture replacements are used at least 8 hours a day.

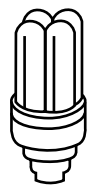

**Replace Incandescent Lamps With Compact Fluorescent Lamps (CFLs).**

CFLs have been specifically made in a compact form to replace incandescent lamps in traditional screw-in fixtures. Compact fluorescent technology has improved recently, and the lamps currently available in the marketplace are brighter and have very good color rendition properties. For example, most modern hotels have installed CFLs for corridor lighting. The fixture pictured on this page contains a CFL and costs less than \$40. Compact fluorescent fixtures with reflectors provide an excellent substitute for floodlamps. Care should be exercised when considering CFLs for worship spaces. Perhaps you can test a few for acceptability prior to making wholesale changeouts.

The table at right shows the equivalency of CFLs to incandescent lamps. You can replace these yourself; most major hardware stores stock CFLs that can be used in place of incandescent

lamps and cost less than \$20. Utility rebates can reduce your cost even further.

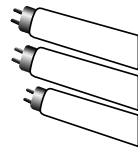

**Replace Incandescent Lamps With Tubular Fluorescent Lamps.**

Fluorescent lamps are the common tube lamps found in nearly every nonresidential building. They are usually about three to four times more efficient than incandescent lamps and can last eight to 20 times longer. With newer fluorescent lamps, you can also specify color correction to avoid the pasty image traditionally associated with fluorescent lamps.

Tubular fluorescent lamps have much lower maintenance costs than incandescent or compact fluorescent lamps. Replace your incandescent lamp and your lighting, energy, operating, and maintenance costs may decrease by about 75 percent.



Would you believe this attractive fixture is made specifically for compact fluorescent lamps and costs less than \$40?

If You Have Incandescent Lamps	Replace Them With These Compact Fluorescent Lamps
25 watts	5 watts
40 watts	7 watts
60 watts	13 watts
75 watts	22 watts
100 watts	27 watts

Lamp Type	Energy Costs	First Cost	Life	Color	Replacement Costs
Incandescent	Much Higher	Lower	Shorter	Good	Higher
Fluorescent	Much Lower	Higher	Longer	Better to Worse	Lower

**EXIT** **Replace Incandescent Exit Signs With Light Emitting Diode (LED)**

**Exit Signs.** LED exit signs use light emitting diodes commonly seen in electronic devices such as clock radios.

You can buy an upgrade kit to convert existing exit signs for \$25 to \$75 and do it yourself, or you can purchase new fixtures and install them for less than \$100. Because the upgrade kits don't require any wiring, they are easier than new signs to install yourself if there is room inside

the panel to install them. LED exit signs use about 5 percent of the energy used by incandescent exit signs and 20 percent of the energy used by compact fluorescent exit signs. LED exit signs also last 10 to 20 times longer.

The best LED exit signs on the market today are produced by manufacturers that follow EPA ENERGY STAR guidelines for energy efficiency and conform to Underwriters Laboratory (UL) standards for safety. Look for the ENERGY STAR label when purchasing your new exit sign. Given their installation costs, lower maintenance costs, and low energy costs, they generally pay for themselves in one to 3 years. For more information on ENERGY STAR manufacturers, you can visit our Web site at [www.epa.gov](http://www.epa.gov). See the bar chart on this page for annual operating costs for exit signs.

**Annual Operating Cost Per Exit Sign**

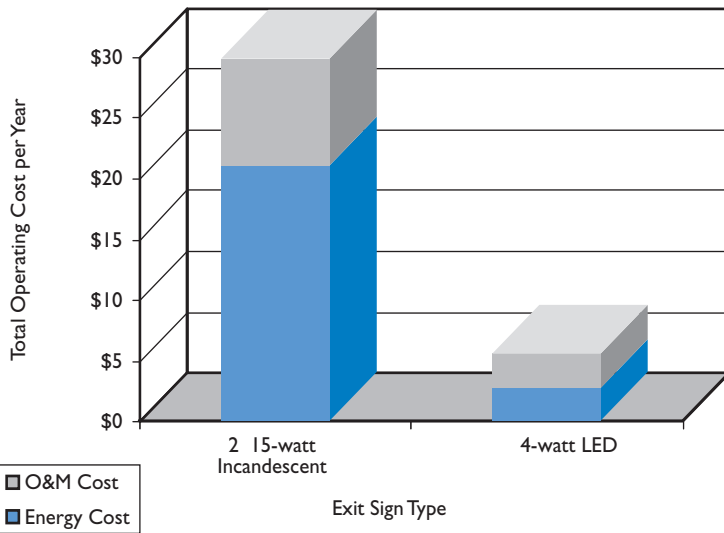

**Upgrade Fluorescent Lamps**

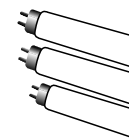

Even within the generally efficient category of fluorescent lighting, you can reduce your energy use by more than 66 percent

by changing from the worst to the best type of fluorescent tubes. Fluorescent lamps were introduced at the World's Fair in New York City and the Golden Gate International Exposition in San Francisco in 1939. Surprisingly, their designs changed little over the years until recent breakthroughs that have significantly improved their efficiency and the quality of the light they produce.

**T-8 Lamps And Electronic Ballasts.**

T-8 lamps use smaller diameters, phosphors, and coating to improve efficiency by about 10 percent compared with standard T-12 lamps. Their electronic ballasts use about 30 percent less energy than old magnetic

**Tech Talk: Components Of A Light Fixture**

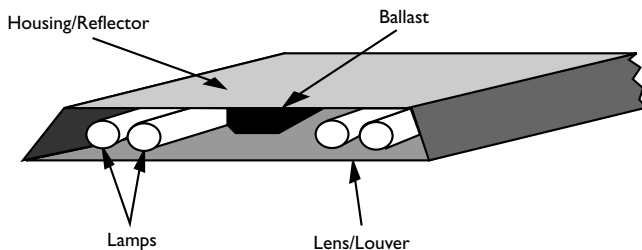

ballasts do. (Ballasts are devices that provide the proper voltage and current to fluorescent lamps, which don't regulate themselves like incandescent lamps.) T-8 conversions cost \$50 to \$100 per fixture, so you might wonder if it is worth the trouble. The answer depends on your local electricity costs and how often you use the lights. Generally, if you use the lamps 60

hours per week or more, the answer is "yes" or at least "yes, it's worth finding out more information." All you need to do is ask your local lighting contractor or electric utility company to perform a detailed analysis for you. This can usually be done free of charge.

**Other Ideas.** T-8 lamps and electronic ballasts aren't your only solution. Modest gains are achieved from 34-watt "energy saver" lamps. As discussed later in this section, de-lamping and/or reflectors can also help. Some designers are switching from fluorescent tubes to lower power metal halide fixtures for a more industrial look. Consider the example scenario shown at the bottom of this page. There are four different retrofit options; none is the single "right" answer. They are all viable, cost-saving, quality-enhancing ideas. Choosing among them is a financial and design decision.

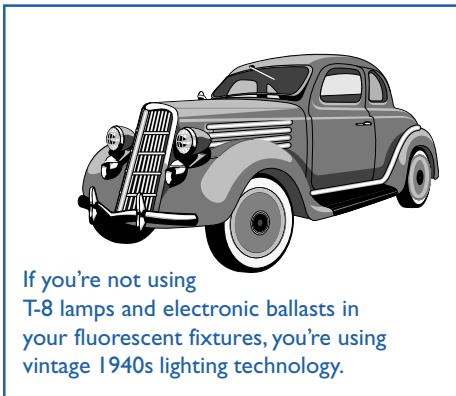

### Explore Your Options

A congregation has 20, 4-lamp, 4-foot fluorescent fixtures in an office area. They are on about 50 hours a week. Recommended light level is between 50 and 75 footcandles.

Current Light Level	95 footcandles
Current Energy Use	9,984 kWh/year
Current Annual Energy Costs (at \$0.08/kWh)	\$799

Upgrade Options	Energy Savings kWh/Year	Cost \$	Annual Savings \$	Simple Payback Years	Light Level	Light Quality
Option 1: Install 34-watt "energy saver" lamps. Light level is lowered to about 85 footcandles.	1,664	\$360	\$133	2.7	Improved	Slightly better
Option 2: Install four T-8 lamps and an electronic ballast in each fixture. Light level remains the same.	3,744	\$1,280	\$300	4.3	Still too high	Much better
Option 3: Install two T-8 lamps in each fixture, with a specular reflector. Fixtures are "tandem wired" so two fixtures share a single ballast. Light level becomes 55 footcandles.	6,916	\$1,340	\$553	2.4	Ideal	Much better
Option 4: Install new deep-cell parabolic fixtures with T-8 lamps and electronic ballasts. Fixtures are "tandem wired" and light level becomes 55 footcandles.	6,916	\$2,600	\$553	4.7	Ideal	Ideal

*If you replace your outside security incandescent lamps with sodium lamps, your costs may decrease by 80 to 90 percent.*

## Install High-Intensity Lamps

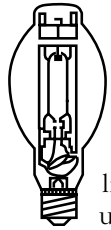

If your facility has high ceilings and doesn't have fluorescent lamps, you probably use HID lamps. If you have older types of HID lighting, you have several upgrade options.

**Upgrade From Mercury Vapor.** At a bare minimum, you should replace mercury vapor lamps with more efficient metal halide lamps as the old lamps burn out. Even if you need to replace the ballast or the whole fixture, it turns out to be economical for almost everyone and no one can even tell you're doing it. Metal halide lamps render colors better than mercury vapor lamps. They come in a variety of power outputs, from 50 to 2,000 watts, and have long lives.

They also come with clear or coated bulbs. The coated bulb has the best color rendition property and can be used for display lighting.

You've probably seen metal halide lights without even realizing it. Most of the new "big box" retail stores are

illuminated using metal halides. They are the bright white lights typically hung from the ceiling girders at 20 to 30 feet. Their typical payback is 5 years, and the intangible benefit of better security lighting is very valuable and immediate.

Also, manufacturers have recently started selling small metal halide spotlights. The bright white light combined with the narrow beam and sparkle can make selected objects really stand out—the benefits of halogen with lower energy costs!

### Use Metal Halide Or High-Pressure Sodium In Large, Open Areas.

Choose high-pressure sodium where light quality is not critical and rock-bottom energy use is the goal. The typical payback based on 12-hour-per-day use is about 3 years.

Use metal halide instead in high-profile or color-sensitive areas or in areas where people need to perform detailed work, and install high-pressure sodium lamps outside. High-pressure sodium lamps are popular for outdoor and security lighting. They come in a variety of power outputs, from 35 to 1,000 watts, and have about a 20,000-hour life.

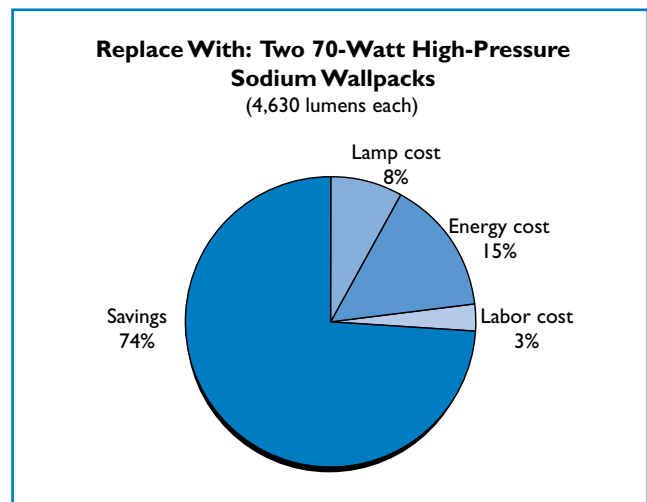
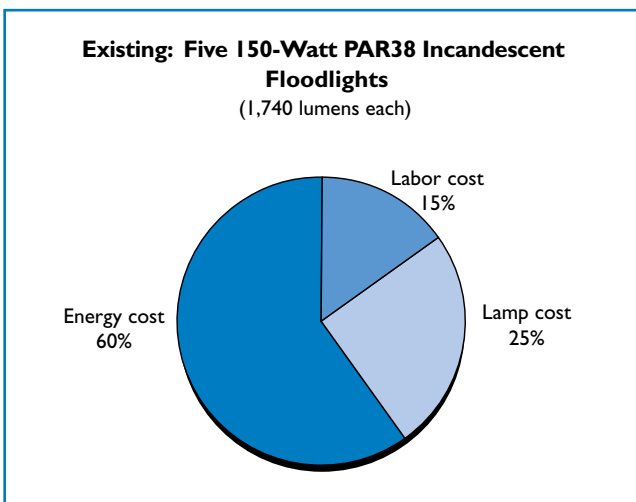



Sodium lamps are the most efficient lamps you can buy. Most of them have a light yellow tint, but some of the newer lamps have an attractive white color rendition. These new lamps tend to fade from white after a certain number of hours of use, so be sure to discuss the issue with your contractor prior to installation in nonstorage areas.

Watch out for low-pressure sodium lamps. They are efficient but have a very murky yellow color and are usually not recommended.

If you replace your outside security incandescent lamps with high-pressure sodium lamps, your costs may decrease between 80 and 90 percent. The typical payback time is less than 2 years, and you will likely have much better lighting than you do now.

For outdoor applications, consider installing shields to reduce excessive glare and focus the light where you want it. An action as simple as focusing exterior lighting downward at night can potentially save a tremendous amount of energy. The International Dark Sky Association is dedicated to protecting our night sky from wasteful light pollution. For more information on how your congregation can save money while enhancing our view of the universe, please visit [www.darksky.org](http://www.darksky.org).

## Remove Lamps

What could be a better deal than getting savings with no upfront cost? In many offices, two lamps in a 4-lamp fluorescent fixture may be removed and lighting may still meet recommended levels. People working on computers will probably prefer the lower level because it increases the contrast on their monitors. You can experiment to see if removing lamps makes sense in your facility. Corridors also are good places to start because these areas often are overlit. Cost: \$0. Simple payback time: 0.0 years.

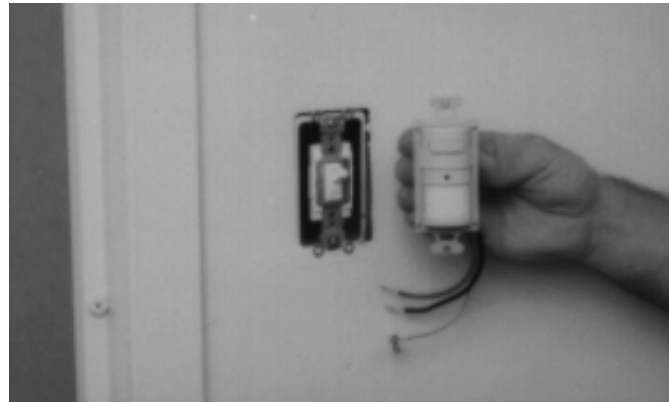

Your electrician can quickly replace an existing wall switch with an occupancy sensor. You'll save money because the sensor will turn the lights off when the room is unoccupied.

Lowering the number of lamps also can be an excellent measure when combined with installation of reflectors. Reflectors are not for everyone. We've found reflectors are best applied to areas that start with about 50 percent too much light and 4-lamp fluorescent fixtures. If that sounds like your facility, remove half of the lamps and add reflectors to meet your target amount of light. Ask a lighting professional if they would be applicable in your facility.

### Energy-Savings Potential With Occupancy Sensors

Application	Energy Savings
Offices (private)	25-50%
Offices (open spaces)	20-25%
Restrooms	30-75%
Corridors	30-40%
Storage areas	45-65%
Meeting rooms	45-65%
Conference rooms	45-65%
Warehouses	50-75%

Note: Figures listed represent maximum energy-savings potential under optimum circumstances. Figures are based on manufacturer estimates. Actual savings may vary.

Sources: CEC/DOE/EPRI

## Controls To Turn Lights Off

One easy way to save money and help your lights last longer is to turn them off when they are not needed. Occupancy sensors use ultrasonic or infrared sensors to detect people in a room. These sensors cost between \$25 and \$80 and are an excellent choice for bathrooms or meeting rooms that are likely to be unoccupied for large portions of the day. If desired, these sensors can be purchased with an on-off switch.

Photocells are designed to turn exterior lights on automatically when it gets dark. Motion sensors are suited to exterior security lighting, loading dock areas, and doorways. These sensors turn lights on automatically when movement is detected. Automatic dimming systems that adjust lamp output based on measured sunlight also are available.

## Summary

Your lighting needs may be suited to other technologies involving advanced controls or alternative lighting equipment. Many fixtures simply can have some of the lamps removed with installation of reflectors. You may have exterior lighting suited to installation of low-pressure sodium fixtures, which are efficient types of lighting used

when lighting quality is not important at all. You can find out about these and other technologies by calling the toll-free ENERGY STAR hotline at 1-888-STAR-YES.

## Take The First Step Toward Implementation

The following steps will help you decide whether you should proceed further with your lighting upgrade project.

1. Do a simple lighting assessment or investigate and analyze other opportunities. Call 1-888-STAR-YES for more information. Then, calculate simple payback for the project. (Refer to the box below.)
2. Call your local contractor or one of EPA's ENERGY STAR product and service providers if your simple payback is 5 years or less. Remember, you won't save a dime until the new hardware is installed. Every day you wait, you lose money that can never be recovered.

## Where Can I Learn More?

For more information on EPA's ENERGY STAR for congregations, lighting technologies, and lighting contractors, call 1-888-STAR-YES and ask for technical information on the equipment you are considering replacing.

### How To Calculate Simple Payback

#### The Short Version

$$\text{Simple Payback} = \text{Measure cost} \times 1,000 \div [(\text{watts before} - \text{watts after}) \times \text{hours/year} \times \text{energy cost}]$$

Example:

$$\text{Payback} = \$400 \times 1,000 \div [(500\text{w before} - 100\text{w after}) \times 6,000 \text{ hrs./yr. use} \times \$0.08/\text{kWh}] = 2.1 \text{ years}$$

## Success Story

### Energy For The Kids At Sligo Adventist School

When Kenneth Gair, plant manager for the Sligo Adventist School, talks about his involvement with ENERGY STAR, his face lights up. He has good reasons to smile—his facility received an ENERGY STAR Partner of the Year award in 1995 for the work done to upgrade the lighting system in the school. Maybe his best reason to smile is that all the wasted energy that went into inefficient lighting systems now helps to power the school's new computer lab!

The lighting system at Sligo was more than 30 years old and very inefficient. Gair decided to upgrade the system by starting with the areas that would give him the quickest pay-back. He started with the hallways by replacing incandescent lamps with T-8 lamps and electronic ballasts. This upgrade improved light levels and certainly caught everyone's attention. People were very happy with their new working environment. He then moved on to the cafeteria and the gym. Both areas were lit with 300-watt incandescent lamps, which he replaced with metal halides. In the gym, for example, he replaced 36, 300-watt incandescent lamps with 10, 400-watt metal halides. Gair also upgraded outside lighting to high-pressure sodium fixtures.

Classroom lighting was upgraded to T-8 lamps, and electronic ballasts and sensors were added to each room. The hardest part about installing the sensors, Gair says, was fine-tuning the sensitivity and the delay time of the sensor. At first he got a few complaints from teachers and students because the lights would typically go off in the afternoon when teachers were alone in their rooms. Gair was able to establish the right delay time to have the classrooms lit when needed and to ensure that the lights would be off only at appropriate times.

Technical information for carrying out the upgrades came mostly from EPA's ENERGY STAR program. Gair received a video explaining the significance of sensors and how to choose the right one for his application. He used passive

infrared sensors in the classrooms and ultrasonic sensors for the restrooms.

Gair used several innovative ways to fund his upgrades. He gained the support of the school's parent-teacher council and used the money he received to finance his first project. Then, he applied for rebates at his local utility. The money from the rebate was then funneled back to the next project, and so on. Gair was able to do most of the work himself. He managed to get extra labor at an affordable price by hiring students from a neighboring high school.

Now that Gair has completed the lighting stage of the program (Stage One), he is looking into window replacement (Stage Three) and heating and cooling system upgrades (Stages Four and Five). Although these will be more expensive upgrades, the success of his early project will help Gair show that energy efficiency really does pay.

When we asked about his next project, he happily marched us to the schoolyard to show us an all-recycled playground!



# Building Tune-Up



All cars should get a tune-up and an oil change every few thousand miles to keep them running smoothly and help them last longer. When was the last time you gave your building and equipment a tune-up? You'll get the same kind of savings from a building tune-up as you would from an automobile tune-up—modest savings at a low cost—and an opportunity to extend the life of your investment. Every once in a while you may even get a boost in horsepower.

### Check Your Timers And Thermostats.

Have you adjusted them for daylight saving time? What about the last time there was a power outage? Did your weekly calendar compensate for last February 29? Does the temperature seem right? Most mechanical timers won't correct for power outages. Resetting them will improve comfort and save you some money. Ask your heating contractor to recalibrate your thermostat on the next visit.

**Check Your Filters.** Unless the filters are inaccessible, you don't need to call your heating and cooling contractor out for an expensive visit just to make sure you have clean filters. Check them yourself every month or two. Each dirty filter you replace will make your air cleaner, work your fan less, and keep the inside of the system cleaner so that it operates more efficiently. Although a new filter might cost only \$2, each dirty filter can cost you \$5 a month in extra energy consumption and can decrease the life of your system.

**Check Your Bills.** Do you know how much your energy bill is now compared with a year ago? Once or twice a year, take time to compare your bills. You might want to compare them with neighboring congregations' bills as well.



Replacing filters regularly is an easy way to get high air quality, low energy use, and long life for your heating and cooling equipment.

## Success Story

### Something To Dance About

During a periodic review, a dance studio manager in New York City noticed that his total electric bill had gradually increased to the point of doubling over the course of a year. He was now paying about \$500 per month instead of the \$250 he used to pay. His business hadn't changed and the rates looked about the same, so he called the local utility for help. The utility company sent out an energy surveyor who performed a free assessment. The surveyor concluded that wiring inadvertently allowed the expanding business next door to use the studio's power. That 5-minute comparison and free assessment saved the studio \$200 per month!

## Success Story



**DOORSTEP**  
*"a way in... a way out"*

### Homeless Shelter Becomes Energy-Efficient Haven

The Doorstep Homeless Shelter in Highland Park, MI, provides housing and food for those down on their luck in the Detroit area. The shelter also provides medical treatment, food, and housing for the mentally ill. With such a clear mission to serve the community, the Doorstep Shelter is a haven where residents find refuge and help. Judy Bugaiski, controller of the shelter, explained, "As our logo suggests, we provide a way in and a way out. But in these times of economic hardships, nonprofit organizations must look into all operational expenses to save money without sacrificing the valuable services they provide to people in crisis." Shelters like Bugaiski's rely heavily on donations. Without a reliable source of funding, these shelters need to be as cautious as possible with their operating budgets.

Bugaiski first learned about potential energy savings for the shelter when she was contacted by Tom Cleaver of Environmental Contract Services (ECS), an energy savings performance contracting company and a member of ENERGY STAR. An energy survey by ECS identified several low-risk, high-return, energy-efficient upgrades. Bugaiski soon realized that the upgrades were a wise investment that would generate substantial returns in lower energy bills. Because the shelter provides housing, Bugaiski knew that improving the lighting and heating systems, two of the largest energy users in the facility, would reduce operating costs (especially during the coldest winter months).

### Creating A Radiant Refuge

Bugaiski hired ECS to perform the upgrades that had been recommended in the energy survey. ECS replaced incandescent bulbs, T-12 lamps, and magnetic ballasts with compact fluorescent lamps, T-8 lamps, and electronic ballasts. Bugaiski explained, "The new lighting system provided brighter light. Management, technical staff, and residents alike have commented favorably to the change. It is nice to know that technology can provide a bit of relief to those in need." The cost to upgrade the lighting system was \$7,500, but the shelter will save \$5,073 per year.

### Warm Hearts Provide A Warm Place

Providing a helping hand, an ear to listen, and a warm heart is what the staff at the Doorstep Shelter have been trained to do. But they also want to provide a warm place for the homeless to stay. By replacing an old, low-efficiency boiler with a new, high-efficiency one, and by cleaning radiator traps in the rooms, Bugaiski and her staff provided residents with a warm, comfortable place to stay while reducing the shelter's heating costs. The new boiler cost \$25,100, but it saves Bugaiski \$11,200 per year in heating costs.

### Helping Hands Come To The Rescue

Heavily dependent on donations, shelters such as Bugaiski's must, by necessity, have tight operating budgets. Finding the financial resources for the upgrades was tough, Bugaiski said. Since she was committed to the idea of upgrading the lights and heating system, Bugaiski organized two fundraising activities—a Christmas donation fund and a benefit choir event. The money from the donations and ticket sales went straight to the energy upgrade budget. Once the word spread, Bugaiski received additional private donations.

"What's great about energy-efficient upgrades," Bugaiski explained, "is that they don't have to be done all at once. Each phase of the upgrade can be staged according to the available budget and immediate needs." Initial upgrade costs often can be recovered in just a few years, so the incentive to install energy-efficient equipment is great. As Bugaiski learned, energy-efficient upgrades can increase the comfort level for residents while cutting energy costs—and that frees up money to help the homeless in other ways.

Bugaiski looks forward to continuing other energy-efficiency upgrades that the shelter desperately needs, but for that, she says she must wait for more hearts to open up and donate to those in need.

# Office Equipment



**T**here are a lot of mysterious things about computers, but energy use isn't one of them. The computer that sits on your desk may look innocent enough, but it silently consumes \$40 per year in electricity. Although \$40 isn't enough money for you to justify throwing out your old computer and buying a new, efficient one (there are plenty of other reasons for you to do this), it is enough money that you should consider energy use when the time comes to shop for a new computer.

Office equipment is the fastest growing electrical load in nonresidential facilities. Unfortunately, computers, fax machines, printers, and copiers waste energy when they remain on and idle. To reduce this waste of energy and the pollution associated with it, manufacturers of just about every major brand of office equipment have partnered with EPA to introduce ENERGY STAR labeled machines that will automatically power down when not in use. The chart on this page shows the typical savings you can achieve if you buy ENERGY STAR labeled office equipment instead of inefficient equivalents. It does add up. What would happen to your mission budget if you could cut all of your facility operation costs by 50 percent?

In addition to its direct energy consumption, office equipment gives off heat. Your air-conditioning unit must work harder to remove this unwanted heat. Introducing energy-efficient office equipment provides the added benefit of lowering utility bills due to reduced air-conditioning loads. This is Stage Three of the ENERGY STAR program.

Even better, you don't have to spend anything extra to get this savings. You don't have to sacrifice any performance, and payback time is 0.0 years. Your choices remain virtually the same as before because so many major manufacturers have chosen to join ENERGY STAR. Just specify ENERGY STAR labeled products or look for the logo on display models. EPA offers a number of informational fact sheets and brochures on ENERGY STAR labeled office equipment and maintains a regularly updated, detailed list of qualified products. For more information, call the ENERGY STAR hotline at 1-888-STAR-YES or visit the Web site at [www.energystar.gov](http://www.energystar.gov) (click on "products" to locate office equipment).

## Begin Saving Today

Teach your congregation's equipment users to modify their behavior to include turning off computers, printers, and copiers at night, over the weekend, and at other times when the equipment is not being used. If you have multiple computers, consider

*Energy-efficient office equipment may lower utility bills due to reduced air-conditioning loads.*

### Typical Savings If You Buy ENERGY STAR labeled Office Equipment

Office Equipment	Annual ENERGY STAR Labeled Office Equipment Cost Savings	Percentage Of Total Operating Cost
Computer	\$19	49%
Fax machine	\$13	52%
Printer	\$39	65%
Copier (medium)	\$57	57%
Copier (large)	\$130	58%

Use our online calculators at [www.epa.gov/congregations](http://www.epa.gov/congregations)

networking your computers to share printers so that fewer printers remain idle during the day.

Your computer may already have energy saver software installed; if so, make sure that it is enabled.

## How Does It Work?

The following facts on ENERGY STAR labeled office equipment will help you to be a better shopper and decision-maker when buying and operating new equipment.

**Computers.** ENERGY STAR labeled computers automatically power down to 30 watts or less when not in use and are available from almost every manufacturer. To optimize your ENERGY STAR labeled computer, make sure that the power management feature is enabled and that you have set it to the shortest acceptable time for your operation. Laptops use less energy than desktops.

**Monitors.** These are among the biggest savers. When not in use, ENERGY STAR labeled monitors automatically power down to 30 watts or less. If you are going to implement a screen saver, make sure you select one that is compatible with the monitor's power management feature. Most screen savers actually prevent the monitor from going into sleep mode. Furthermore, turning monitors off at night and during the weekend is a practice that will provide you with dual benefits. It not

What You Will Save					
	Energy Savings (kWh/yr)	Cost Savings Per Year At Different Electric Rates (\$/kWh)			Percent Savings
		\$0.06	\$0.08	\$0.10	
<b>Save Now</b>					
<b>Turn 24-hour equipment off at night so it runs only 9 hours per day.</b>					
Savings per computer	675	\$41	\$54	\$68	61%
Savings per large copier	1,688	\$101	\$135	\$169	49%
<b>Save Later</b>					
<b>Replace older 24-hour equipment with new ENERGY STAR labeled equipment that is used 9 hours per day.</b>					
Savings per computer	795	\$48	\$64	\$80	72%
Savings per large copier	1,980	\$119	\$158	\$198	58%



**Make the Right Call.** This 20-computer telemarketing center uses a lot of energy for computers and cooling. ENERGY STAR labeled computers would cut the center's annual electric bills by about \$500.

only reduces energy costs, but in fact, extends the life of the units by preserving the same phosphorus substance that screen savers were designed to save. Finally, when buying a new monitor, consider the size of the unit as part of your purchasing criteria. Large monitors use more energy, so buy the smallest monitor that suits your operation.

**Printers.** ENERGY STAR labeled printers that go into sleep mode when not in use save you energy and money. ENERGY STAR labeled printers that have double-sided printing capabilities also reduce your paper costs. Networking one printer for several users is one of the best strategies you can implement to reduce energy consumption and save your congregation money. Not only will you benefit from reducing your energy costs, but you also will lower your capital expenditures by purchasing fewer printers.

**Facsimile Machines.** Because fax machines remain on 24 hours a day, they hold huge energy savings potential—up to 50 percent. ENERGY STAR labeled fax machines save energy in

two ways. They go into sleep mode after being idle for a set period of time, and they scan double-sided pages. You will not miss any faxes if the fax machine goes into sleep mode.

**Copiers.** ENERGY STAR labeled copiers are equipped with a feature that allows them to automatically turn off after a period of inactivity, which reduces their annual electricity costs by more than 60 percent. There are also several strategies that you can implement regardless of the type of copier you operate. You can purchase a correctly sized copier, use the 1- to 2-sided copy option to ensure that the duplexing feature is being used, and run copies in batches to decrease the time your copier spends in the high-powered mode.



# Paper



**Y**ou may not think of your paper use as an area with potential energy savings, but it is. Paper producers in this country buy more than \$3.5 billion worth of energy each year. In fact, every \$5 ream of paper you avoid using eliminates about \$0.34 worth of energy production and related emissions by a paper mill—not to mention the energy spent to harvest and ship the trees and to ship the paper to your desk. In this section, we review simple steps to optimize your use of this valuable resource. You will save money, reduce waste, and protect our nation’s forests so they can be enjoyed by generations to come.

Recycled papers and other products are rated by their “post-consumer content” and “total recycled content.” These percentages are usually in very small print on the paper packages. Post-consumer content is the more important factor and refers to fibers that have been used and then collected through recycling programs. Total recycled content refers to the total nonvirgin content of the paper, including production scraps and post-consumer fibers. Paper does not have to be conspicuously labeled “environmentally friendly” to have a high recycled content, so a little research can identify some real bargains.

---

*Paper can have a high recycled content even if it is not conspicuously labeled “environmentally friendly.”*

## Double-Sided Copying

Copiers often have the capability to automatically copy on both sides of a piece of paper. Selecting two-sided copying for long documents, articles, or drafts can instantly reduce your paper use without adding any associated inconvenience. For more information, see the text box at right.

---

### Double-Sided Copying Makes Great Stewardship Sense Because It:

- Reduces the amount and cost of paper used
- Lowers mailing costs because the paper amount and weight are reduced
- Reduces paper output, which takes up less storage space in offices
- Appears more professional
- Reduces the environmental impacts of paper throughout the production process; therefore, fewer trees are harvested, there are lower chemical and energy inputs during pulping, and transportation and storage costs are reduced
- Shows a congregation’s commitment to environmental protection

## Recycled Paper

Many paper products contain some recycled content. Recycling allows fibers to be reused in the production cycle so that fewer trees are required to provide the same amount of paper. Cardboard and newsprint may contain as much as 75-percent recycled content, while standard copy paper often has less than 5-percent recycled content. Selecting papers with high recycled content can be the simplest way you can help preserve our forests.

---

Andrew Duncan, *Greening of the Campus Conference Proceedings*. Ball State University, Indiana. 1996.

---



Conserving paper is an important step in saving energy, lowering pollution, and ensuring the long-term health of our forests.

## Recycling

Many municipalities sponsor programs to collect paper and fiber products such as corrugated cardboard; paperboard (cereal boxes); white, colored, or glossy paper; newsprint; and books bound with glue. Collecting and returning your used paper to a recycling center will return that fiber for reuse and may reduce your waste disposal costs. Large users of one or more of these products can set up their own collection program with a local salvage company. They are paid by the ton for the materials that they collect and they save from reduced disposal costs.

Consider including a statement on printed materials such as “Printed on 50-percent recycled paper containing 20-percent post-consumer waste” to highlight your congregation’s commitment to the environment.

## Reduce Your Paper Use

There also are other ways that organizations can reduce their paper use and streamline their operations. Announcements routinely issued to all members can simply be posted on area bulletin boards. Instead of making a copy for each person, you can circulate many documents by using a routing tag containing the names of relevant people. An employee/volunteer checks off his or her name and passes the material to the next person on the list.

Many congregations have revolutionized their operations through e-mail and local area networks (LANs). In addition to greatly improving internal communication and facilitating team projects, these tools can significantly reduce paper use by replacing memos, event calendars, forms, and draft documents.

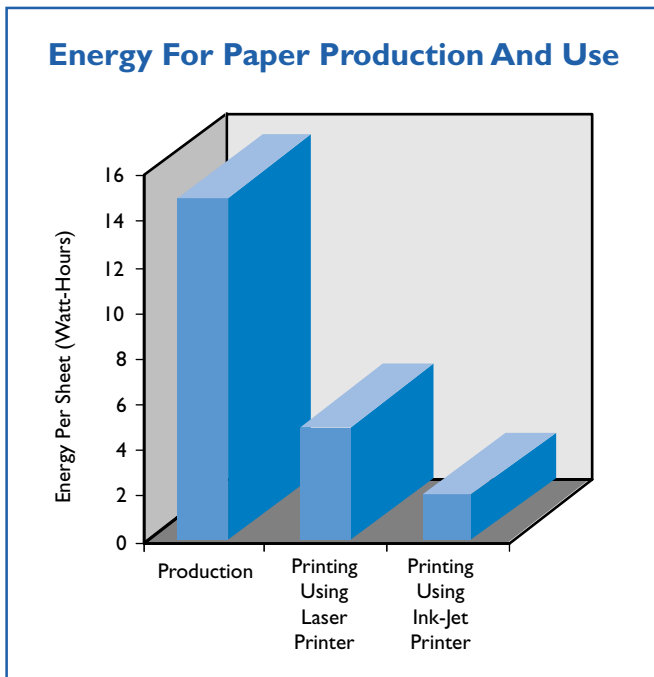

# Water Heaters And Water Use



**M**ost congregations use hot water, even if only for hand washing. Some congregations have kitchen facilities and some operate homeless shelters, day care or elder care facilities, schools, and other facilities that use hot water for purposes such as dishwashing, showers, and laundry. Hot water can represent 25 percent or more of your total energy bill. Fortunately, there are many low-cost, easy-to-apply methods for reducing your congregation’s hot water costs.

## Water Heaters

**Turn Off Your Water Heater When It’s Not Needed.** Although this may seem obvious, it really is a great idea. Buy a 7-day timer (you can get one for about \$30) to turn off your electric water heater at night and on days it is not needed and to turn it back on one hour before your operation starts up in the morning. If you have a big water heater, you can get even more aggressive and turn it off an hour or two before people leave. The already heated water should be sufficient to “coast” through further use. You’ll save anywhere from \$10 to \$50 per year with a water heater timer. Along the same lines, consider shutting off a dedicated water heater that is rarely used and turning it on only when needed.

If you use a circulating pump, be sure that it is shut off when the facility is unoccupied. Again, a timer will help you remember. Circulating pumps increase heat loss through pipes that circulate hot water. A one-eighth horsepower pump that is turned off for 2,000 hours per year will save you \$25 in pump energy alone.

**Lower The Thermostat Setting.** The hotter the water temperature, the faster you lose energy through the pipes and water heater tank walls. Therefore, lower the thermostat to provide hot water at the lowest acceptable temperature. Some tasks (such as doing laundry or washing dishes) and some buildings (such as health care facilities) require higher water temperatures than others. These temperatures may be set by state and local codes. However, a small office with an electric water heater that is used only for handwashing purposes would save about \$10 per year if the setting is changed from 130 degrees to 120 degrees. See the chart on page 58 for some recommended hot water temperatures.

If one task, such as laundry, requires significantly higher temperatures than other tasks, it may be more efficient to reconfigure your piping to include a blending valve. The hottest water would be piped directly from the heater to the high-temperature task; the water for the remaining tasks would branch off and pass through a blending valve, which mixes in cold water to reduce the water temperature

---

*The Tap Water Burn Resource Center recommends 110°F and below as a safe temperature for typical hot water use ([www.tap-water-burn.com](http://www.tap-water-burn.com)).*

---

## Summary

To optimize energy use of your water heater:

- Minimize hot water waste
  - Provide hot water at the lowest temperature acceptable for the task
  - Insulate the tank and pipes
  - Obtain hot water from the most efficient sources
  - Perform periodic maintenance procedures
-

### Typical Recommended Hot Water Temperatures

Process	Temperature (Degrees Fahrenheit)
Hand Washing	105
Showers	110
Laundry*	160
Dishwasher Rinse**	180-195

\*Check code requirements.

\*\*Many dishwashers have booster heaters. Check with the manufacturer to determine minimum temperature requirements.

Source: ASHRAE.

*Before you buy a new water heater, consult the EnergyGuide label so that you select an efficient model.*

for the other tasks. Alternatively, you may wish to install separate heaters for high-temperature and low-temperature tasks or to provide booster heaters for high-temperature tasks. Some machines provide their own booster-heating mechanisms.

**Insulate Your Tank.** To reduce heat losses in your hot water system, make sure that your hot water storage tank and the hot water pipes connected to it are insulated. Nowadays, few hot water tanks are totally uninsulated.

**Move Your Water Heater.** If you are remodeling, take the opportunity to relocate your water heater as close as possible to the main point of water consumption. This will reduce heat loss from the pipes.

**Buy A New Water Heater.** If you buy a new water heater, be sure to consult the EnergyGuide label on the appliance so that you select an efficient model. Consider using a heat pump water heater, particularly in situations where the simultaneous cooling it will provide would be useful. A relatively new and more efficient technology, heat pump water heaters remove heat from the surrounding air and transfer it

to the water. Because these water heaters also cool and dehumidify the surrounding air, they are particularly beneficial in warm, humid areas such as kitchens and laundry rooms.

Another excellent alternative is tankless, instantaneous, on-demand water heaters, which are quite popular in Europe. They are growing in popularity here, too, especially in areas where relatively small amounts of hot water are used on occasion. Tankless water heaters eliminate tank and piping losses and are great for buildings that have only sinks. They typically supply up to two gallons per minute of hot water, about the same as required for a shower and more than enough for most sinks. One catch is that they may require heavier wiring, so check with your contractor before making a decision. For information on whether instantaneous water heaters are right for your facility, please call 1-888-STAR-YES.

Or don't buy a new water heater. Consider turning your standard water off except for emergencies and using "free" waste heat recovery to meet some of your water heating needs. Waste heat sources include laundry or dishwashing rinse water, steam condensate lines, and refrigeration equipment.

### Maintenance

To maximize savings and keep your hot water system operating efficiently, you should perform periodic maintenance procedures as prescribed by the owners' manual. Storage-type water heater tanks should be flushed out annually to remove sediments that reduce system efficiency. (Flushing involves opening the drain valve at the bottom of the tank and drawing off water until the water runs clear. Follow your manufacturer's instructions. In areas with high mineral content in the

water, you may need to do this more often.) The burners of gas or oil-fired water heaters should be tested and adjusted annually to make sure that the fuel is being burned as efficiently as possible. In addition, it is a good practice to periodically flush your fixtures with very hot water to control bacteria growth.

## Solar Water Heating

You really can't do any better than solar power for energy savings and for the environment. Solar water heaters are simple devices that capture the sun's energy to heat water for ordinary use. They often are piped directly into systems with conventional water heaters, lowering your energy costs while still providing hot water on overcast days. Solar water heaters are extremely cost-effective for heating swimming pools, where other types of heating can be very expensive.

Solar water heating is an established technology used throughout the world. In California, solar systems are the only type of pool water heating allowed by many local codes. Even the pool built for the Atlanta Olympics is heated with a solar system, although this was a unique, showcase system. While you may think of the large number of units in sunny areas like Florida or California, you may be surprised that even in the rainy areas of the Pacific Northwest, solar water heaters can pay for themselves in less than 10 years. Check with your local utility or your state energy office to find out about incentives that apply to the installation of solar energy systems. You can get more information, locate a solar installer, or find a supplier for a do-it-yourself system by contacting the American Solar Energy Society at (303) 443-3130 (Web site: [www.ases.org](http://www.ases.org)). For additional information on solar initiatives, see [www.solarstewards.org](http://www.solarstewards.org).

## Water Use

You may wonder why an energy manual is discussing water use. Certainly within your own facility it costs money to heat the water. But your water company also spends a lot of money on energy to pump and purify the water it delivers to you. So a portion of your water bill is actually an energy bill. The same logic holds true for sewage treatment. If your congregation uses large amounts of water, you will benefit even more from water use optimization.

Like everything else, savings from water measures can vary. You can save on the cost of the water, you can save on sewage, and you can also save on energy costs for pumping or heating processes. Because savings come from so many sources, water reduction upgrades are frequently profitable.

Efficient showerheads and faucet aerators are inexpensive devices (they generally cost between \$2 and \$20) that screw into existing pipe fittings to help reduce water consumption. These devices reduce the amount of water wasted in common daily tasks. If your congregational facilities include hot water sinks and showers, you can use these devices to significantly reduce your water heating bills as well as your water bills.

---

*Solar water heaters use the sun's energy to heat water and can help you lower your energy costs.*



Installing an aerator on a faucet takes just 10 minutes and costs less than \$10. Aerators help prevent water waste and save water heating costs, even though the flow from the faucet appears to be the same.

## Success Story

### Water Heater Tune-Up

Consider the case of a manager of a 2,000-sq.ft. congregation building who discovered a leak in the pipes from a 40-gallon electric water heater. While repairing the leak, she decided to install an insulated blanket wrap around the water heater to prevent additional heat loss. The cost of the installation, the insulation, and the repair was approximately \$40. By setting the water heater thermostat to a setpoint of 120 degrees Fahrenheit, the office manager saved \$35 per year and had a one-year payback. That extra \$35 goes back into the congregation's funds year after year.

---

*Repairing a seal that leaks a drop of electrically heated hot water every five seconds can save you about 400 gallons of water, 59 kilowatt-hours of electricity, 87 pounds of carbon dioxide, and \$7 per year (at 8¢/kWh).*

By repairing a seal that leaks a drop of electrically heated hot water every five seconds, you can save about 400 gallons of water, 59 kWh of electricity, 87 pounds of carbon dioxide, and \$7 per year (at 8¢ per kWh).

Automatic controls such as valves or springs with sensors that turn faucets off can also help save water. The spring-loaded valves will automatically turn the water off when the user releases the handle. Photocell-equipped sensors are gaining popularity in controlling water use in restrooms. Almost all major airports have installed them due to their high rate of use and because luggage and other articles tend to fill travelers' hands. These sensors detect motion and shut the water off after the user leaves.

The amount of water used when flushing toilets can be drastically reduced without compromising efficacy by using new, low-volume toilet fittings. These fittings can reduce the amount of water used per flush by about 66 percent by using improved water flow characteristics. High-quality, pressurized, low-volume toilets tend

to cost about \$200 more than gravity toilets, but they are worth the premium if the toilets will be flushed more than 20 times per day.

New washing machines with a horizontal axis design use much less water than older types of washing machines. The new machines can help save water as well as reduce water heating costs for facilities such as day care centers. They can also reduce the amount of detergent that is used for washing the same amount of clothes. The newer design machines occupy less space and do not produce as much heat as the older design washing machines, which use much more hot water; thus, your rent and air-conditioning requirements can also be reduced. New machines also remove more water from the laundry during the spin cycle, thereby greatly reducing drying time and energy use.

### Xeriscaping And Gray Water

Your congregational facilities may need landscaping. Xeriscaping (xer means "dry," from Greek) is the technique of utilizing native, hardy, low-maintenance plants for landscaping. Xeriscaping can save you money on your water and maintenance costs. And because native plants cope better with your particular soil, climate, and insects, they require fewer pesticides and less fertilizer (something your 4-legged neighbors and feathered friends will appreciate). If you enter "xeriscape" into your Internet search engine, you will find dozens of Web sites offering information and programs. For example, try [www.greenbuilder.com/sourcebook/xeriscape.html](http://www.greenbuilder.com/sourcebook/xeriscape.html), [www.windstar.org/wildlife](http://www.windstar.org/wildlife), or [www.nwf.org/nwf/habitats/index.html](http://www.nwf.org/nwf/habitats/index.html).

Water from sinks or washing machines that may contain soap but is otherwise still clean is called “gray water.” Many drought-prone areas of the country have encouraged use of this gray water for landscaping purposes. St. Petersburg, FL, has even installed a citywide system that provides reclaimed water for 7,000 homes and businesses. Other cities do not permit reuse of gray water at all because of water quality concerns. For more information on promotional programs or restrictions on gray water use, call your local building permits office or check out the EPA Web site at [www.epa.gov](http://www.epa.gov).

## Where Can I Learn More?

If you want more information on smart water heating, the Gas Appliance Manufacturers Association (GAMA) publishes a *Consumers’ Directory of Certified Efficiency Ratings* for electric, gas, and propane water heaters ([www.gamanet.org](http://www.gamanet.org)).

We also recommend:

- **U.S. Department of Energy** (for information about hot water heaters): [www.eren.doe.gov/consumerinfo/factsheet.html](http://www.eren.doe.gov/consumerinfo/factsheet.html)
- **Indoor Water Efficiency Spreadsheet** (contains information on calculating energy savings): <http://solstice.crest.org/environment/gotwh/general/indoor-water/index.html>
- **Iowa Energy Center** (for information about buying, installing, and upgrading hot water systems): [www.energy.iastate.edu/efficiency/residential/homeseries/waterheaters/index.htm](http://www.energy.iastate.edu/efficiency/residential/homeseries/waterheaters/index.htm)
- **WaterWiser, The Water Efficiency Clearinghouse** (for information on water efficiency and conservation): 1-800-559-9855; [www.waterwiser.org](http://www.waterwiser.org)

# Refrigeration



**R**efrigeration equipment is one of the highest energy users in your kitchen. Upgrades that reduce your refrigeration costs can make your congregation's kitchen more efficient. One of the most exciting aspects of refrigeration is that there have been so many great developments over the past 25 years to make systems more efficient. The downside of all these innovations is that you may have a hard time keeping up with them. So look for help.

A new residential-size refrigerator with the ENERGY STAR logo is guaranteed to use 30 percent less energy than federal government standards require.

If your equipment is more than 10 years old, call a local refrigeration case supplier and request a checkup. You'll be surprised at all the possibilities. A typical new residential refrigerator uses about 800 kWh and costs about \$64 per year to run. This is less than half what you'd pay to run the same size unit that is 20 years old.

## No-Cost Action Items For The Refrigeration Amateur

**Keep The Doors Shut.** Repeated fluctuations in temperature will damage your food quality and cost you money.

**Check The Temperature Settings.** If your settings are lower than necessary, chances are you are wasting energy. The most common recommended settings are between -14 degrees and

-8 degrees Fahrenheit for freezers and between 35 degrees and 38 degrees Fahrenheit for refrigerators.

**Load Your Refrigerator Properly.** Overloaded units disrupt air flow patterns needed to cool efficiently, and deterioration occurs. On the other hand, underloaded units waste energy. If you have several partially filled units, consolidate them and turn one or more off.

**Position Refrigeration Units Properly.** Don't put your refrigerator right next to your stove or in direct sunlight. Your refrigerator will have to work harder to maintain the desired cool temperature. Make sure that there is enough ventilation available for your refrigerator's mechanical equipment. A 1-inch gap on the sides and a 4-inch gap at the back are recommended to allow the condenser and fan to have access to a steady flow of air.

**Clean The Cooling Coils.** Dirt accumulation impairs proper heat transfer and lowers the efficiency and capacity of refrigerators.

**Check The Door Seals.** Tight seals and properly closing doors prevent warm air from entering the unit, which reduces cooling energy and prevents frost buildup. Use this rule of thumb: If you can easily slide a dollar bill into the seal, have the seal adjusted.

Performing each of the above activities can save you between \$5 and \$25 per year. These activities also can improve your product quality and extend the unit life. At no cost except a few minutes of your time, these activities are a bargain.

---

*A new residential-size refrigerator with the ENERGY STAR logo is guaranteed to use 30 percent less energy than required by federal government standards.*

**Shorten Defrost Cycles.** This is starting to get a bit technical. Fifteen minutes an hour isn't perfect for everyone or for every season. If you're in a dry climate or season, gradually decrease your defrost cycle time until you see hints of frost buildup on the coils. Back the setting up a bit and you are optimized. This procedure, like others, can help extend the unit life.

If you are in the market for a residential-type refrigerator, look for the ENERGY STAR logo—your guarantee of savings. And use the EnergyGuide label to help you identify its annual operating costs and if a particular model compares with other models on the market and their annual operating costs. Base your purchasing decisions on the price you can afford to pay and the highest efficiency available in your range. Calculate the simple payback for the cost premium to see how much increased efficiency you should buy.

Purchase freezers and refrigerators with Energy Efficiency Ratings (EERs) ranging from 7-9 for medium temperature systems and from 5-6 for low-temperature systems.

### A Note About CFCs

The major challenge the refrigeration industry has faced is the mandated phaseout of chlorofluorocarbons (CFCs). Until recently, many refrigerators used CFC-based refrigerants. The foam insulation built into older refrigerators also contains CFCs. Because CFCs deplete the ozone layer and contribute to global warming, new refrigerants have been developed to replace CFCs and are currently available in new units or as replacements for CFCs in old units. Call the EPA Stratospheric Ozone Hotline at 1-800-296-1996 for information on converting your existing refrigerators and on disposal methods.

## ENERGYGUIDE

▼

Compare the Energy Use of this Refrigerator  
with Others Before You Buy.

This Model Uses  
776kWh/year

▼

Energy use (kWh/year) range of all similar models

<b>Uses Least</b>	<b>Uses Most</b>
<b>Energy</b>	<b>Energy</b>
<b>776</b>	<b>1467</b>

Refrigerators using more energy cost more to operate. This model's estimated yearly operating cost is:

**\$64**

Use the EnergyGuide label to select efficient residential-size refrigerators. (Also available for other appliances.)

# Building Construction



**T**he phrase “set in stone” is frequently used to describe things that must be accepted as facts of life. This may be how you view your building’s construction and the way it affects your energy bill. Just because your building is set on a firm foundation doesn’t mean that you can’t make some changes—large or small—to reduce the impact that your building’s exterior has on your heating and cooling costs. What’s more, most of the changes you make to reduce your energy costs also will bring improvements in comfort and your building’s appearance.

Fortunately, there are many small-scale upgrades that you can make to your building’s envelope (walls, roof, and windows) to reduce your heating and cooling costs. Unlike the equipment inside your facility, simply changing a wall or a roof just because the original equipment isn’t efficient enough isn’t really a feasible solution. However, sometimes windows of opportunity do occur to upgrade your building’s construction at relatively little extra expense.

For example, roofs need to be replaced periodically and the additional expense of adding insulation or reflective coverings at that time can be justified by the savings they will provide. Similarly, energy-saving window upgrades may be worthwhile when your building’s facade is being remodeled to modernize its appearance. When it is time to replace your heating or cooling system, you may find that by investing some money in wall or roof improvements, you can reduce your building’s heating and cooling needs enough to reduce the size and cost of the unit you need

to buy. Alternatively, if your current system can’t quite heat or cool enough on extreme temperature days but is still new enough that you would rather not replace it, you can make building improvements to reduce your heating and cooling loads enough to allow your current system to meet your needs.

Most of the upgrades that you can make to your facility involve reducing heat losses in winter, reducing heat gains in summer, and reducing air leakage throughout the year. The particular envelope upgrades that make the most sense for your building depend on both the climate and the layout of your facility. A congregation in Phoenix, AZ, will be more concerned about what the summer sun is doing to its cooling bill than one in Caribou, ME.

---

*You can reduce heat losses in winter, reduce heat gains in summer, and reduce air leakage throughout the year by upgrading your facility.*

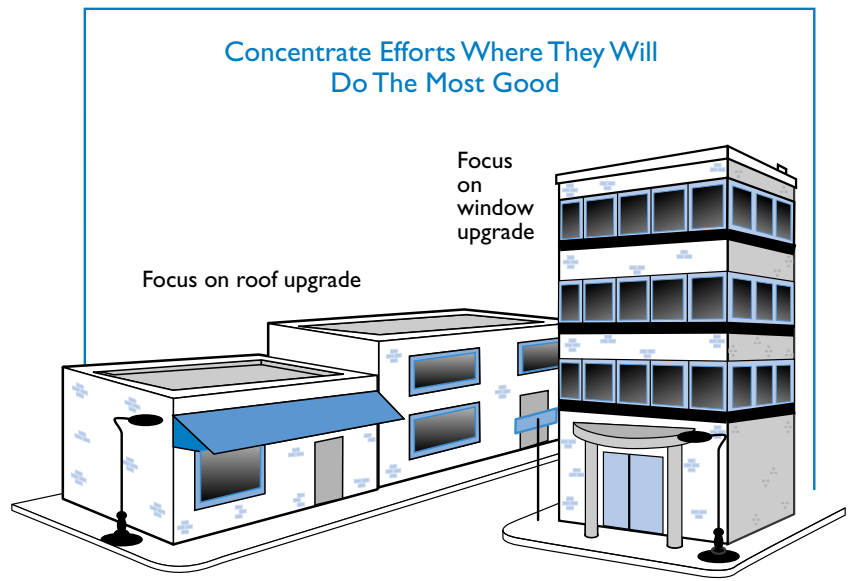

## Success Story

The Georgetown Gospel Chapel of Seattle, WA, will reap the rewards of energy efficiency for many years to come. Savings thus far are estimated between \$3,000 and \$5,000, not to mention the prevention of 60,000 pounds of CO<sub>2</sub> each year. The Chapel saved by conducting a comprehensive upgrade of facilities that included lighting, insulation, heating, windows, and water measures. “We eliminated one gas furnace due to our conservation and efficiency practices and greatly reduced electrical heating,” said Reverend Leroy Hedman.

### Windows

Windows are one of the most appealing parts of any building, providing its “look,” and, of course, natural light. But windows also are an area where a lot of your heating and cooling costs can literally “go out the window.” Windows typically have low insulating levels, as anyone who has sat next to a large, single-pane window on a cold winter day can attest. In addition, windows can allow a lot of unwanted summer heat gain, especially if they’re located on the west or south side of the building. In recent years, window manufacturers have developed low-emissivity (low-E) windows with dramatically higher insulating values and reduced heat gains, but it is unlikely that these are being used in your building if it was built before 1990.

#### Window R-Values\*

<b>Single Pane</b>	<b>1.0</b>
<b>Double Pane</b>	<b>2.0</b>
<b>Triple Pane</b>	<b>2.9</b>

Decrease R-Values by at least 20 percent if aluminum frames.  
 Increase R-Values by about 30 percent if low emissivity.

\*When purchasing new windows, manufacturers often categorize windows with U-Values (the ability of a material to conduct heat) or simply the reciprocal of the R-Value.

Unless you have single-pane windows and are located in a cold climate, the savings from replacing your windows with more efficient ones are hard to justify financially unless the replacement is done as part of a larger renovation. You can improve the efficiency of your existing windows, however, by installing window films.

Window films are thin coatings that can be applied to the interior surface of windows to help block radiant heat gains and losses. These coatings are similar to those used in low-E windows. Their primary benefit is in reducing summer heat gains because they can prevent from 61 to 80 percent of the incoming solar radiation from entering your building. In winter, these coatings can help reduce heat losses by preventing 19 to 44 percent of indoor heat from escaping out the window. In addition to providing energy-cost savings, window films improve comfort by moderating heat losses and gains, reducing glare and overheating, increasing privacy by restricting visibility from the outside, improving the appearance of the windows, and reducing the fading of carpets, furniture, and merchandise. Window films typically cost between \$1.35 and \$3 per square foot to install, and they generally have a lifetime of 7 to 12 years. They must be installed properly to avoid bubbles, cracks, or damage to your windows. It is not advisable to use window films to cover stained-glass windows due to the unevenness of their surfaces and the possibility of trapping moisture between the window and the film.

Window accessories also affect your energy costs. White roller shades and Venetian blinds, when fully drawn, reflect heat. Draperies or curtains, when made of a tightly woven, opaque material in a light, reflective color, can reduce heat gain. If a curtain fits tightly against the window, it also can reduce winter heat losses. Awnings on the south, east, and west sides of your

building can reduce summer heat gains; trees planted on the east and west sides of the building also can reduce summer heat gains. The chart below provides a simple guide to when you should use your shades, depending on the season and the time of day. For more information on windows, see [www.energystar.gov](http://www.energystar.gov) (click on products to locate windows). Another excellent source is [www.efficientwindows.org](http://www.efficientwindows.org).

## Roofs And Walls

Your building's roof generally can be improved in two ways: by improving the insulation and by improving its reflectivity to reduce heat gains. Your priorities will depend on the type of building you have and where it is located. Roofing improvements are generally better investments for buildings that currently have a poorly insulated roof and in locations with extreme temperatures in either summer or winter.

If heating costs are a priority at your facility, or if you work in a warm climate and have an attic, roof insulation could be a good investment. If your congregation has attic space, insulation may be added at any time to the attic floor at a relatively low cost either by blowing in insulation or by installing batts of insulation on the attic floor. Depending on the type of roof you have, insulation may be

added on either the inside or the outside. If you have a flat roof, your best bet will probably be to wait until your roof needs replacement and to install rigid insulation on the roof exterior when it is being replaced.

How much insulation is enough? Your state or local building codes usually require a specified level of insulation, but keep in mind that this figure is a minimum required amount. Because codes have gradually increased the amount of insulation required, many old buildings have less than the amount required by current codes. To get a better idea of advisable insulation levels for energy cost savings in your area, check with your state energy office or local electric utility. ASHRAE recommends an R-Value between 25 and 30 for optimum cost effectiveness. See the chart on page 68 for some roofing rules of thumb for frequently occupied spaces. For an intermittently occupied space such as a worship space, minimum insulation as prescribed by code is sufficient.

If your air conditioner runs significantly more than your heating system, ask your roofing contractor about reflective roof coverings. Covering the roof with a light-colored stone, coating, or membrane is less expensive than a full roof replacement. The lighter color will cause your roof to absorb less heat and extend the life of the roof by slowing its deterioration. Another alternative is a roof spray system, which has moisture sensors that control spraying water over the roof to keep temperatures down. Of course, this affects water use and your water bill, but the tradeoff can be calculated to help you decide.

If your building has attic space, you may be able to install a radiant barrier. A radiant barrier is essentially a layer of aluminum foil tacked to the underside of your roof deck with the shiny side facing down toward the air space in your attic. It blocks 95 percent of the

---

*Roof insulation could be a good investment if heating costs are a priority at your facility or if you work in a warm climate and have an attic. For more information on insulation, see [www.ornl.gov/roofs+walls/insulation/ins\\_05.html](http://www.ornl.gov/roofs+walls/insulation/ins_05.html)*

Pull Your Shades		
DAY		
<b>SUMMER</b>	<b>Down</b>	Block the sun
<b>WINTER</b>	<b>Up</b>	Let in the sun
NIGHT		
<b>SUMMER</b>	<b>Up</b>	Let building heat out
<b>WINTER</b>	<b>Down</b>	Keep building heat in

### Roofing Rules Of Thumb

Existing Condition	Cost Effective To Add Insulation?
New Construction →	Yes, always. R-19 to R-38 depending on location and codes.
Existing Buildings:	
<i>Current Insulation Level</i>	
0-1 inches →	Yes, always.
2-4 inches →	Yes, if attic is accessible or if built-up roof is being repaired.
5-9 inches →	No, in moderate climates. Just add when remodeling.  Yes, in extreme climates and where the attic is accessible.
More than 9 inches →	No.

**When unconditioned air from outside slips into your building, or conditioned air from inside seeps out, you have to pay to heat or cool the extra, or replacement, air.**

heat that otherwise would be radiated downward from your hot roofdeck. All of these options result in lowered roof or attic temperatures, which make your upper floor a much more comfortable place during the summer. In one application in New Orleans, for example, the installation of a radiant barrier and attic vents dropped the attic temperature by 50 degrees. You can imagine the effect on comfort downstairs. Finally, forced ventilation in attics can decrease temperatures by 30 degrees or more, for a big increase in comfort and savings.

### Reducing Air Leaks

When unconditioned air from outside slips into your building, or conditioned air seeps out, you have to pay to heat or cool that extra, or replacement, air. Consequently, it pays to minimize these leaks, especially because the methods used to reduce it are generally inexpensive and easily applied. Reducing leaks also will improve your occupants' comfort, because nobody feels comfortable sitting in a draft.

Use caulk to seal air-leaking cracks and to install or replace weatherstripping around doors and operable windows. Small air gaps may look inconsequential, but they add up. A 1/8-inch air gap along the opening of a pair of 6-foot, 8-inch doors is equivalent to a 10-square-inch hole in the wall. Replace the glass in any broken windows as soon as possible. Make sure all doors and windows close properly and—an often forgotten procedure—cover the exterior portion of any window air conditioners in the winter.

### If You Plan To Remodel

Increasing the insulating value of existing walls is difficult to justify from a cost-savings point of view. However, you may wish to do so if a cold wall is a significant comfort problem. If you have frame walls, you can have insulation blown into the wall cavities. Otherwise, you can increase the insulating value by adding a layer of insulation over the existing interior wall and covering it with new wallboard. (You will also need to move any light switches or electric boxes out.) This solution will slightly decrease the size of the room. See the figures on page 69 for variations of wallboard coverings.

Consider installing a vestibule at your primary entrance because of the number of times doors are opened for religious services, meetings, and other functions. A vestibule consists of a space between two sets of doors that acts as an airlock to reduce the amount of air that enters or escapes from the building as people enter or leave. You may be able to create one by installing an extra set of doors inside your building, or you may wish to build it as a small addition. This area does not need to be heated or air conditioned. In addition to reducing energy costs, this

modification will dramatically increase the comfort of anyone who sits or stands near the doors. Studies show that vestibules can reduce related infiltration by more than half. Such a measure likely will not be justifiable based solely on energy cost savings unless it is part of a larger upgrade, but it is justifiable when you consider the added comfortable space it provides.

Your options for reducing your building's energy costs are limited to some extent by the choices made when it was built. Making the decision to use energy-efficient windows and appropriate insulation levels is far less expensive when a building addition is still on the drawing board. At that point, the actual cost of each upgrade should be considered the incremental cost between the more and less efficient alternatives.

The options that provide the best return on investment can be identified by comparing the incremental cost with the energy cost savings that will accrue over the building's lifetime. Software packages are available that can be used to analyze these choices. If your architect is unfamiliar with them, you may wish to hire a consultant to help you make the optimal choices.

**Technical Closeup: R-Values**

**R**-Values measure the effectiveness of insulation. The higher an object's R-Value, the better it resists heat loss (or gain). Heat loss through an object is inversely proportional to its R-Value, so you get more bang for your buck from increasing the R-Value of a building component that initially has a lower R-Value than you would with a higher one. Increasing insulation from R-1 to R-20 will save you a lot more money than increasing from R-20 to R-40. For example, adding an R-Value of 1 to a window that currently has an R-Value of R-1 represents a 50-percent decrease in heat loss; adding R-1 to an R-15 wall decreases its heat loss by 6.25 percent.

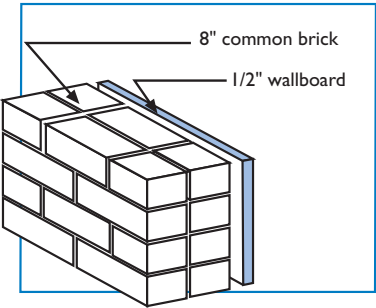

Drawing 1

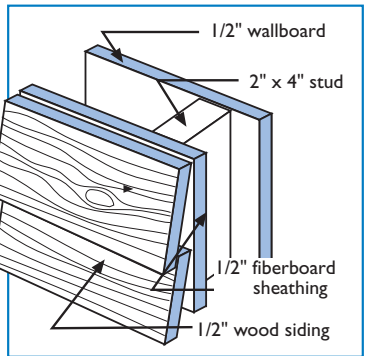

Drawing 2

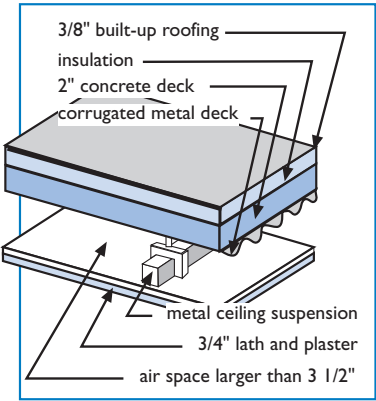

Drawing 3

	R-Value	
	Without Insulation	With Insulation
Drawing 1	R-5	R-12
Drawing 2	R-4	R-8
Drawing 3	R-5	R-9

# Heating And Cooling



**H**eating, ventilating, and air-conditioning (HVAC) systems account for 39 percent of the electric energy used in commercial buildings in the United States. Consequently, almost every congregation has the potential to realize significant savings by improving its control of HVAC operations and improving the efficiency of the systems it uses.

**Invest In Energy Optimization.** It makes good financial sense for so many reasons. You'll typically get a 30-percent return or better on your investment, and ENERGY STAR for congregations will help you find sources that can provide financing if initial funding is a problem.

**Don't Worry.** You don't have to become an energy expert or spend a lot of time working on new projects to get all these benefits. Because you're a congregations partner, we'll help you find reliable energy analysts and contractors so you can turn your attention back to your congregational work. When you do need technical support to be a smarter shopper, we're here with the information you want. Call us at 1-888-STAR-YES or visit our Web site at [www.epa.gov/congregations](http://www.epa.gov/congregations).

What's left to decide? Call an expert and get started!

## 1970s-Style Conservation: It Still Works

The most straightforward method for saving on your HVAC bill is simply to operate the systems less by turning the systems off or back when the building is not occupied; by using natural ventilation, ceiling fans, or economizers whenever possible; and by choosing more efficient temperature setpoints so the systems run less often.

A week contains 168 hours. Even if you have some facilities that operate during 40 or even 80 of those hours, you still occupy your facility during only a fraction of the week. Consequently, savings are available by setting back your thermostat when the building is unoccupied. The term "setting back" is used to indicate both changing the temperature setting (setting back to a lower temperature in winter and setting up to a higher one in summer) and making sure that the fan switch on the thermostat is set to "auto" rather than "on." A fan left in the "on" mode runs nonstop 24 hours per day; in "auto" mode, the fan cycles on only when heating or cooling is being supplied. In some instances the fan savings can be significant even when only minimal temperature setback changes are made. If your system draws in ventilation air from outdoors, cycling the fan during unoccupied

---

*Save on your HVAC bill by turning the systems off (or back) when the building is unoccupied.*

hours can also help with humidity control in humid areas.

Substantial savings also are available by adjusting your temperature setpoints—lower in the winter and higher in the summer. Change your thermostat settings gradually, no more than a degree or so per week, to see how low (or high for summer) a setting you need to maintain a comfortable facility. Make these changes without advertising the fact that you are doing so to avoid having staffers or congregation members begin grumbling about changes before they can actually feel them. This method also can help identify problem areas. Check out the areas where you first receive complaints about comfort to determine whether the problem is one of inadequate air supply, excessive drafts, or intense sunlight.

Hire a contractor to repair old valves and steam traps, if you have them. A steam trap costs approximately \$50. If broken, it can waste hundreds of dollars each winter. One supplier estimated that an average of 20 percent of traps nationwide are broken. Broken steam traps not only waste money and energy, they also cause extreme discomfort.

How much can you save? That depends on your climate, the size and shape of your building, how much you set back your thermostat, and how many hours per week your building operates.

### **1980s Efficiency Improvements: Programmable Thermostats**

Although night-setback and temperature-setpoint changes are simple enough to be done manually, an automatic control is much more efficient and reliable. Electronic, programmable thermostats—

which allow you to program in desired setpoint and cutoff times for a 7-day week—are available for \$50 to \$200. Most models include manual override features, so a staff member or volunteer who needs to come in at a time when the system is in setback mode can override the setback and gather in comfort without having to reprogram the system. Be sure to locate the thermostat in a location where the temperature is representative of the entire area served by the system—not next to the air-conditioning diffuser or a coffee pot. Many congregations find it worthwhile to install a locking enclosure around their thermostats to avoid unauthorized tampering with the setpoints. If you have a heat pump, be sure you get a heat-pump-programmable thermostat with a “smart recovery” feature, which will bring your system on early enough to minimize the use of electric strip heating. Heat-pump thermostats cost about twice as much as other thermostats because they have to control multiple types of heating.

### **1990s And Beyond: Whole-Building Energy Optimization And Management Systems**

Programmable thermostats are effective and work quite well, especially with individual-unit air conditioners and heaters. If your facility uses larger, central systems such as boilers and chillers, you may wish to use an energy management system (EMS) instead. In the 21st century, the EMS market will likely expand into smaller and smaller facilities. In addition to the setpoint and night-setback features, which can be handled by a programmable thermostat, an EMS can be used to provide savings in many other ways. Depending on the type of system you have, an EMS might be used to provide

some of the following money-saving automatic control functions:

- Consider installing an economizer. There may be times when you need cooling in the building but the outside temperature is low. An economizer allows your system to circulate outdoor air for free cooling during these periods. If implemented without an EMS, economizers will cost \$500 to \$1,000, installed, on each rooftop unit.
- Adjust supply-air temperatures based on indoor and outdoor temperature and humidity to let the heating and cooling systems operate most efficiently.
- Adjust chilled-water and hot-water temperatures based on indoor and outdoor temperature and humidity to let the cooling and heating systems operate most efficiently.
- Implement holiday period automatic setpoint adjustments.
- Monitor space temperatures to minimize overheating or overcooling of spaces on a zone-by-zone basis.

An EMS can be used to control other functions in your building as well, such as lighting. It can be monitored and controlled from a console in a remote location, such as your home or your maintenance manager's home. EMS suppliers typically estimate that their EMS can cut the heating and cooling bills of a congregation with a central chiller and heating system by 10 to 50 percent (many estimates are clustered in the 20-percent range).

### Approximate Percentage Savings From Thermostat Setback In Non-Worship Space (Savings for systems serving worship spaces can be significantly more)

Degree-Days*	Setback Temperature		
	60	55	50
1,000	13%	25%	38%
2,000	12%	24%	36%
3,000	11%	22%	33%
4,000	10%	20%	30%
5,000	9%	19%	28%
6,000	8%	16%	24%
7,000	7%	15%	22%
8,000	7%	13%	19%
9,000	6%	11%	16%
10,000	5%	9%	14%

\*Look up your degree-days on the map below or call your utility for local data. For a definition of "degree-day," see the glossary in section 3.

Savings based on 65 degrees Fahrenheit and assuming setback for 14 hours per weeknight and all weekend.

Source: *Reducing Energy Costs Means a Better Bottom Line*. National Frozen Foods Association/U.S. Department of Energy.

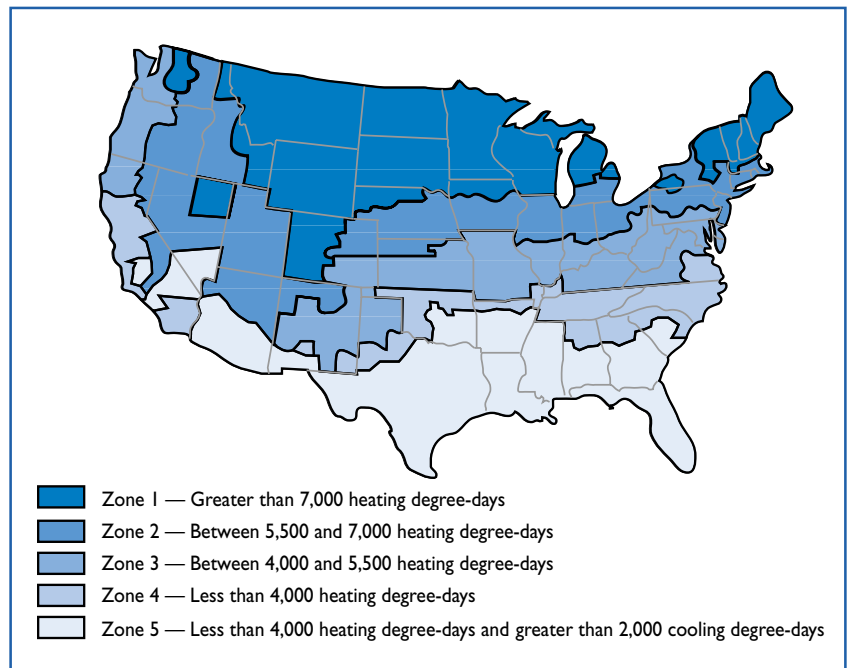

*If you plan to upgrade any heating or cooling equipment, first implement your other ENERGY STAR upgrades. Earlier upgrades (such as lighting replacements or building construction improvements) may change the size requirements for your new heating or cooling system.*

## Improving Your System Efficiency

The remainder of this section offers suggestions on how to improve the efficiency of various types of HVAC systems. Because advice is offered about a variety of different systems, not every suggestion will apply to your facility. One piece of advice does apply uniformly to every congregation, however, regardless of the type of HVAC system: Maintain your HVAC system.

Regular maintenance is an often-overlooked key to saving on your HVAC costs and improving the performance of your system. Although some maintenance jobs may require calling in an outside technician, many can be accomplished inexpensively using in-house staff. Because it also extends the life of your HVAC equipment, regular maintenance provides significant cost savings for minimal investment.

Most procedures will be included in a standard preventive maintenance visit by an air-conditioning contractor. This type of system checkup typically costs less than \$100 for a single system, with additional units included at a discount. Some examples of systems checks and standard maintenance procedures that you or your contractor should do on HVAC systems include:

- **Replacing your air filters regularly.** Accumulated dirt and dust make your fans work harder. Clean filters help system performance and also help reduce allergens in your place of worship. You can do this without a whole system checkup.
- **Cleaning the heat-transfer coils in heat pumps, air conditioners, and chillers.** Make sure that leaves and plants do not obstruct outdoor coils and have any bent coils straightened. In addition to saving energy, this measure will increase the capacity of your system.

- **Inspecting ducts and piping for leakage and missing or damaged insulation and making the indicated repairs.** Insulation is especially important in unconditioned spaces.
- **Making sure that furniture or other obstructions do not block air flow around radiators, convectors, or air intakes and diffusers.**
- **Identifying any areas in your facility that are unused, but are being conditioned.** Consider turning off the HVAC that serves these areas or closing the vents.
- **Adjusting temperature and humidity setpoints seasonally.** Unless it is absolutely required for humidity control, consider turning off “reheat” from late spring to fall.
- **Having your fuel-fired boiler or furnace checked out at least annually, before the heating season starts.** Have the technician check the combustion efficiency and report the results along with any suggestions for improving boiler efficiency.

In addition to the maintenance changes suggested here, making operational changes and/or upgrading some aspects of your HVAC system may result in significant savings. These upgrades are more complex in scope and should be undertaken only after consultation with an engineering professional.

## This Is Stage Five

Do you remember the five-stage approach from pages 31 and 32? If you plan to upgrade heating or cooling equipment, be sure to do this after your other ENERGY STAR upgrades have been implemented because your earlier upgrades (such as lighting replacements or building construction improvements) may result in a change

in size requirements for your new heating or cooling system. If you have a large or architecturally unique site, insist that the contractor complete a sizing worksheet or run a computerized sizing analysis for your facility in its current state of repair. If you think the results inflate your needs, seek another quote.

Never buy oversized heating or cooling equipment on the theory that more capacity is better. This simply is not true. Grossly oversized cooling equipment will cycle too often and be unable to sufficiently dehumidify your space, which creates a serious comfort issue. Such equipment also will cost more to run all year long. Heating equipment will be equally inefficient if oversized. This advice is perhaps the most difficult to follow in this whole guide. Nobody wants to spend \$5,000 on a new air conditioner and find themselves sweating when cooling is sought. But both comfort and costs are at stake. Get the right size, not the right size plus one, and you'll be happy.

If your system was properly sized before making any ENERGY STAR improvements, your contractor may find that your system is now oversized and savings potentially can be realized by downsizing portions. If your system was undersized before you began your ENERGY STAR upgrades, you may find that your improvements have, in effect, balanced your loads and capacity.

**Hot New Technologies: Variable-Speed Drives, Heat Recovery, And Radiant Heating Variable-Speed Drives (VSDs).** If you have a larger system in your building, you may be able to take advantage of available savings through installing VSDs on air blowers or even pumps. VSDs allow sophisticated control of how much air or water is provided by heating and

cooling equipment, which has a significant effect on how much energy is consumed.

**Heat Recovery.** Your congregation may operate a building that requires high levels of fresh air (for example, a nursing home). Installing heat recovery equipment will allow you to recapture some of the energy you have invested in heating or cooling that air and transfer it to the fresh air stream.

**Radiant Heating.** For areas where high ceilings or low insulation levels make heating costly, natural gas-fired radiant heating (which heats occupants directly) is an option to consider.

### Tips For Selecting Heating And Cooling Systems

- Proper sizing is critical to efficient performance
- Check if utility rebates are available
- When buying smaller heating or cooling equipment, look for the ENERGY STAR logo—your guarantee of savings
- Call the ENERGY STAR hotline (1-888-STAR-YES) to request all the materials you need to make you an “energy-smart shopper”

## Success Story

### HVAC Equipment Pays Back In North Carolina

The cost of replacing HVAC equipment can be a burden for any facility, but a smart shopper can use the replacement as an opportunity to reduce operating costs by purchasing energy-efficient equipment.

An ENERGY STAR partner in Durham, NC, needed to replace HVAC equipment in its 2,200-sq.ft. building. The 23-year-old system was a gas furnace with a continuously burning pilot light and an open flue. Cooling was provided by a condensing unit with a poor seasonal energy efficiency ratio (SEER) of 7.

The new heating system included a gas furnace with electronic ignition and a forced draft fan. Cooling equipment with a SEER of 12 was installed. This new system outperforms the old one, cutting both electric and gas usage while increasing comfort. The electronic ignition eliminates the continual gas use by the old pilot light, and the forced draft fan contains any heat lost through the open flue. The new gas furnace cut gas usage by more than 20 percent in its first heating season. Elimination of the pilot light's energy use will add to the total savings. Electric savings due to the increased energy efficiency of the cooling equipment is predicted to be approximately 40 percent.

To find out more about these and other technologies, call the toll-free ENERGY STAR hotline at 1-888-STAR-YES and ask for materials suited to your congregation. And remember, we're here to provide you with unbiased technical information for all your energy-efficiency upgrades.

### Time For Another Repair?

Because of the high cost of large HVAC equipment, the energy savings alone may not justify replacing equipment in good working order. If your equipment requires frequent repairs or is nearing the end of its life expectancy, however, it may be wise to consider replacing it from both a preventive maintenance standpoint and an energy savings standpoint. A scheduled replacement can generally be negotiated at a lower cost and with less inconvenience than the emergency replacement of a failed unit. Call your utility to find out if it offers rebates on high-efficiency equipment.

## Technical Talk: Special Types Of Heating And Cooling Systems

**Systems That Simultaneously Heat And Cool.** In reheat systems, air that is colder than required is supplied to a specific area and then reheated before it enters the room. In dual-duct or multizone systems, heated air is mixed with cooled air. Although these systems provide good temperature and humidity control, this simultaneous heating and cooling is inherently wasteful and should be minimized. If this is being done for humidity control, consider alternatives such as desiccants and heat pipes.

**Single-Zone Chilled-Water Systems.** Consider reducing the air volume and, during relatively dry seasons, raising the cooling supply temperature. Also consider conversion to a variable-air-volume (VAV) system.

**Water-Side Systems.** Consider downsizing oversized pumps and motors, installing variable-speed drives on pump motors, and converting single-loop configurations to a configuration with primary and secondary loops.

**Water-Cooled Centrifugal Chillers.** If your chiller predates 1990, it may be using R-11 or R-12 refrigerants. Manufacture of these has been banned due to the Clean Air Act of 1991, reducing their availability and making their prices skyrocket, so any upgrade should consider converting the chillers to utilize newer refrigerants. Consider replacing your chiller if it is more than 20 years old.

**Boilers.** Consider replacing an oversized, inefficient boiler with a smaller, more efficient boiler. Also consider upgrading an existing boiler with energy savings options such as a newer, more efficient burner (which will also reduce emissions), baffle inserts (to increase the efficiency of fire-tube boilers), combustion controls (to optimize efficiency each hour), warm-weather controls for hot-water boilers (to reduce the water temperature during milder weather), economizers (to preheat feedwater), and condensate return systems (for open-loop steam boiler systems). If you have multiple boilers, keep in mind that it is more cost effective to run one of them at full load than both at partial load. Multiple boilers can be staged in response to return water temperature.

**Large Central Systems.** If you have a large central system and you find that one area of your facility operates for substantially more hours than the others, it may be cost effective to install a smaller, dedicated system in that area.

# Other Ideas For Energy Stewardship



Ideas on energy optimization and related profit enhancements are far more numerous than the ones presented in this guide. The possibilities are endless. In this section we will point out a few more specific ideas, but don't let us constrain you. There may be an opportunity for improvement anywhere energy is used.

## Cooking Equipment

**Don't Preheat Your Cooking Equipment.** Don't preheat your equipment, whether it is electric or gas, for more than a few minutes. Use a microwave or gas stove in place of electric resistance cooking when possible. Both cost less.

**Buy The Efficient Version.** Many fryers, broilers, soup kettles, and other equipment have optional controls and features that minimize their energy use. They are often worth the additional cost.

**Improve Kitchen Ventilation.** Turn off your exhaust hoods (and makeup air unit, if any) whenever you are not cooking. These units demand tremendous amounts of energy. You need to provide a safe and comfortable environment without odors and smoke, but turn both systems off when they are not needed.

## Motors

Congregations with forced air heating and cooling will likely have motors. The rules of thumb here are simple. First, buy high-efficiency motors whenever you replace old ones. Second, if you use a standard efficiency motor (less than 100 horsepower) 24 hours every day, replace it with its high-efficiency equivalent right away and your investment will pay for itself in less than 5 years. Beyond that, your decision is mainly a factor of the motor-cost premium, hours of use, and your electricity cost, shown in the table below in dollars per kilowatt-hour (\$/kWh).

### Should You Buy A High-Efficiency Motor?

**Example:** 5 Horsepower Motor  
 \$80 Cost Premium For High-Efficiency Motor  
 \$480 Total Cost For High-Efficiency Motor

Motor Use Hours/Year	Annual Cost Savings At Electric Rate Shown			
	\$0.05	\$0.08	\$0.10	\$0.12
1,000	\$5	\$7	\$9	\$11
2,000	\$9	\$15	\$19	\$22
4,000	\$19	\$30	\$37	\$45
6,000	\$28	\$45	\$56	\$67
8,760	\$41	\$65	\$82	\$98

- Always buy standard efficiency
- Buy high-efficiency motor upon burnout
- Buy high-efficiency motor immediately

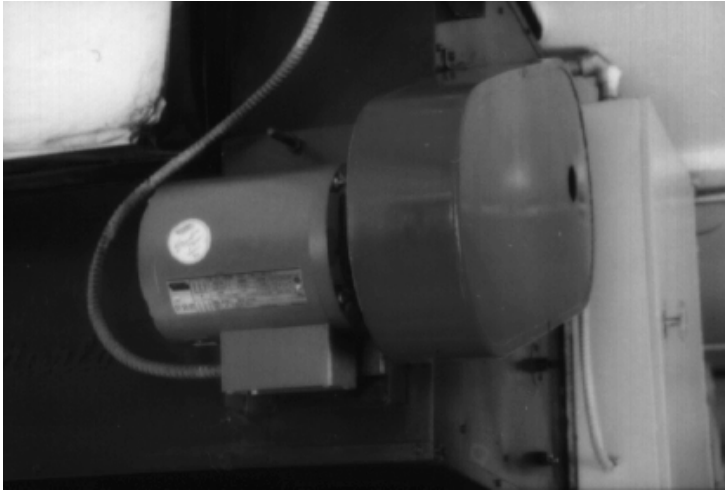

This blower operates 24 hours a day, supplying fresh air to this all-night business. The nameplate on the front of the motor indicates 78-percent efficiency. Replacing it with a new 87-percent efficiency motor could save \$82 a year (at \$0.08/kWh), paying back the investment in 3 to 4 years.

## Fuel Conversions

Electric resistance heating is typically the most expensive option when compared with natural gas, propane, and other fuels. If you already have gas on-site but still use electric-resistance heat for water heating, clothes drying, cooking, or other processes, ask your plumbing or general contractor to tell you what it will cost to convert your equipment. It could be a very good investment for equipment you use often or were going to replace anyway.

## Green Power

Your congregation may want to ask its local utility company about purchasing green power. The term green power is used to define power generated from renewable energy sources. Energy sources for green power often include solar, wind, geothermal, biomass, landfill gas, and hydropower sites. Energy generated from these renewable sources has fewer negative environmental impacts than energy generated from traditional methods. In markets where green power is available, you usually will have to pay a premium, or additional charge, for having your power produced from renewable sources. However, power produced from these renewable sources results in reduced greenhouse gas emissions.

## Other Resources

Solar Initiatives:	<a href="http://www.solarstewards.org">www.solarstewards.org</a> <a href="http://www.eren.doe.gov/millionroofs/">www.eren.doe.gov/millionroofs/</a>
Xeriscape:	<a href="http://www.greenbuilder.com/sourcebook/xeriscape.html">www.greenbuilder.com/sourcebook/xeriscape.html</a> <a href="http://www.windstar.org/wildlife">www.windstar.org/wildlife</a> <a href="http://www.nwf.org/nwf/habitats/index.html">www.nwf.org/nwf/habitats/index.html</a>
Green Power	<a href="http://www.eren.doe.gov/greenpower/">www.eren.doe.gov/greenpower/</a> <a href="http://www.epa.gov/globalwarming/actions/cleanenergy/index.html">www.epa.gov/globalwarming/actions/cleanenergy/index.html</a> <a href="http://www.epa.gov/globalwarming/news/speeches/hogan_080700.html">www.epa.gov/globalwarming/news/speeches/hogan_080700.html</a> <a href="http://www.eren.doe.gov/cleanenergy/">www.eren.doe.gov/cleanenergy/</a> <a href="http://www.green-e.org/what/index.html">www.green-e.org/what/index.html</a>
Green Building	<a href="http://www.usgbc.org">www.usgbc.org</a> <a href="http://www.eren.doe.gov/EE/buildings.html">www.eren.doe.gov/EE/buildings.html</a> <a href="http://www.archrecord.com">www.archrecord.com</a> <a href="http://www.greenconcepts.com">www.greenconcepts.com</a>
Climate Change	<a href="http://www.epa.gov/globalwarming">www.epa.gov/globalwarming</a>



3

# Supporting Material

# Glossary



**AHU:** See *air-handling unit*.

**air side systems:** Equipment used to heat, cool, and transport air within building HVAC systems.

**air-handling unit (AHU):** Equipment used to distribute conditioned air to a space. Includes heating and cooling coils, fans, ducts, and filters.

**ARI:** Air-Conditioning and Refrigeration Institute.

**ASHRAE:** American Society of Heating, Refrigerating, and Air-Conditioning Engineers, Inc.

**ASME:** American Society of Mechanical Engineers.

**balancing:** The process of measuring and adjusting equipment to obtain desired flows. Applies to both air side and water side systems.

**ballast:** A power-regulating device that modifies input voltage and controls current to provide the electrical conditions necessary to start and operate gaseous discharge lamps.

**boiler:** A pressure vessel designed to transfer heat (produced by combustion) or electric resistance to a fluid. In most boilers, the fluid is water in the form of liquid or steam.

**British thermal unit (Btu):** A unit of energy equivalent to the amount of heat required to raise the temperature of one pound of water one degree Fahrenheit.

**Btu:** See *British thermal unit*.

**calibration:** The process of adjusting equipment to ensure that operation is within design parameters.

**carbon dioxide (CO<sub>2</sub>):** A colorless, odorless, incombustible gas formed during respiration, combustion, and organic decomposition. Increasing amounts of carbon dioxide in the atmosphere are believed to contribute to the global warming phenomenon.

**carbon monoxide (CO):** A colorless, odorless, poisonous gas formed during incomplete combustion of fuel.

**CAV:** See *constant volume*.

**central plant:** A centrally located equipment that satisfies a building's cooling and heating loads.

**CERCLA:** The Comprehensive Environmental Response, Compensation and Liability Act (1980). Also known as the Superfund law.

**CFCs:** See *chlorofluorocarbons*.

**cfm:** Cubic feet per minute.

**chiller:** A mechanical device that generates cold liquid, which is circulated through cooling coils to cool the air supplied to a building.

**chlorofluorocarbons:** Chemical compounds consisting of carbon, hydrogen, chlorine, and fluorine, once used widely as aerosol propellants and refrigerants. Believed to deplete the atmospheric ozone layer.

**coefficient of performance (COP):** A measure of efficiency in which a higher value designates a more efficient system.

**coil, condenser:** A heat exchanger used to condense refrigerant from a gas to a liquid.

**coil, cooling:** A heat exchanger used to cool air under forced convection with or without dehumidification. May consist of a single coil section or several coil sections assembled into a bank.

**coil, fan:** A device that combines a heat exchanger and a fan in a single unit that conditions air by forced convection.

**coil, heating:** A heat exchanger that heats air under forced convection. May consist of a single coil section or several coil sections assembled into a bank.

**color rendering index (CRI):** A measure ranging from 0 to 100 of the accuracy with which a light source renders different colors in comparison to natural light, which has a measure of 100.

**combustion air:** Air that supplies the oxygen required to burn fuel.

**commissioning:** The quality assurance process that ensures design intent is met for new facilities or major rehabilitation.

**condenser:** A heat exchanger in a refrigeration system that expels building heat absorbed in the evaporator.

**conditioned air:** Air that serves a space and that has had its temperature and/or humidity altered to meet design specifications.

**constant volume (CAV, constant air volume):** A type of air-handling system that maintains comfort in buildings by providing a constant air flow and varying the air temperature.

**control:** A device that analyzes the difference between an actual process value and a desired process value and brings the actual value closer to the desired value.

**control, pneumatic:** A control that uses air pressure to vary equipment operation.

**control, set back:** The practice of reducing the thermostat setpoint during unoccupied times.

**cooling tower:** A device that dissipates heat from water-cooled systems through a combination of heat and mass transfer, whereby the water to be cooled is distributed in the tower and exposed to circulated ambient air.

**COP:** See *coefficient of performance*.

**CRI:** See *color rendering index*.

**cycling:** The noncontinuous operation of equipment.

**dampers:** Single- or multiple-blade devices, either manually or automatically opened or closed, that control the flow of air.

**deadband:** A setting in the lighting control that provides a time delay, signaling the lights to switch off only if the light level is somewhat *above* the setting, or on only if the level is somewhat *below* the setting.

**degree-day:** A rough measure used to estimate the amount of heating required in a given area. A degree-day is defined as the difference between the mean daily temperature and 65 degrees Fahrenheit (F). This is based on the assumption that no heating is required when the temperature is above 65°F, and that proportionately more heating is required the further the average temperature is from 65°F. Cooling degree-days also may be calculated to estimate cooling requirements.

**DEHP:** Di (2-ethylhexyl) phthalate, an insulator used to replace *PCBs* in ballast capacitors starting in 1979. DEHP is listed as a hazardous waste in its pure form, but, according to *RCRA*, it is no longer considered hazardous when used in a lighting ballast.

**demand charges:** Fees levied by a utility company for electric demand.

**demand ventilation:** A method of controlling the amount of outdoor air intake based on carbon dioxide levels in a space.

**demand, electric:** Electrical power delivered to a system at a given time or averaged over a designated period. Expressed in kilowatts.

**desiccant:** A material that absorbs moisture from its surrounding environment.

**diffuser, HVAC:** A device that distributes conditioned air to a space.

**diffuser, lighting:** A device that distributes light produced by lamps into a space.

**direct expansion system:** A cooling system in which the refrigerant runs in the cooling coil to cool the air directly; that is, there is no water loop between the refrigerant and the air to be cooled.

**domestic hot water:** All hot water consumed in a building that is used for purposes other than heating a space.

**downsizing:** The process of reducing the size (capacity) of equipment so that it operates efficiently at design load conditions.

**ductwork:** The distribution system for air in HVAC systems. It is usually made of sheet metal or fiberglass.

**EER:** Energy efficiency ratio. Cooling capacity (Btu/hr) divided by total input power (watts) requirement.

**efficacy:** The ratio of lamp lumen output to total lamp power input expressed in lumens per watt.

**efficiency:** The ratio of power output to power input.

**EMS:** See *energy management system*.

**energy management system (EMS):** The control system that monitors the environment and energy usage in a building and alters equipment operation to conserve energy while providing occupant comfort.

**ENERGY STAR label:** EPA's registered trademark symbolizing excellence in energy efficiency.

**evaporator:** A heat exchanger in a refrigeration system that absorbs heat from chilled water or building air, thus reducing the supply temperature.

**exhaust air:** Air removed from a building and not reused.

**fan, cooling tower:** Fans that are used to draw air through the cooling tower to carry away water vapor.

**footcandle (fc):** A unit of illuminance equal to one lumen per square foot.

**fouling:** The buildup of a film that reduces heat transfer.

**gasket:** Material used to seal a joint against leakage.

**glazing system:** A configuration of materials with a transparent or translucent element designed to admit sunlight.

**glazing:** Glass set or made to be set in frames.

**GPM:** Gallons per minute. A measure of water flow rate.

**Green Power:** Power that is generated from renewable sources, such as solar, wind, or geothermal sources.

**heat exchanger:** A device that transfers heat from one fluid to another.

**heat gain:** Waste heat produced during the operation of electrical equipment. Typically, heat gain can be minimized by improving efficiency.

**heat, latent:** The heat required to change the phase of a substance (that is, liquid to gas or gas to liquid).

**heat pump:** A device that extracts heat from one medium and transfers it to another portion of the same medium or to a second medium at a higher temperature.

**heat, sensible:** The heat required to change temperature without changing phase.

**heat-exchange area:** An area where heat is transferred from one medium to another.

**HID:** High-intensity discharge.

**hp:** Horsepower. A unit of mechanical power.

**humidistat:** A device that responds to humidity changes and controls equipment by seeking a setpoint.

**HVAC:** Heating, ventilating, and air-conditioning.

**IAQ:** Indoor air quality.

**IEEE:** Institute of Electrical and Electronic Engineers.

**IES:** Illuminating Engineering Society.

**illuminance:** Commonly called light level, the light intensity arriving on a surface measured in footcandles.

**impeller:** The rotating element of a fan or pump used to circulate the air or water.

**infiltration:** Air that leaks into a building through the building shell.

**internal rate of return (IRR):** The compound interest rate at which the total discounted benefits equal total discounted costs for a particular investment.

**IRR:** See *internal rate of return*.

**kilowatt (kW):** A unit of power equal to 1,000 watts.

**kilowatt-hour (kWh):** A unit of electric consumption equal to the work done by one kilowatt acting for one hour.

**kW:** See *kilowatt*.

**kWh:** See *kilowatt-hour*.

**load:** Demand on the operating resources of a system. In the case of energy loads in buildings, the word generally refers to heating, cooling, and electrical (or demand) loads.

**load, cooling:** The cooling (typically measured in Btu/hr or tons) required to maintain an indoor design temperature.

**lumen:** A unit measurement of the rate at which a light source produces light per unit time.

**luminaire:** A complete lighting unit consisting of one or more lamps together with a housing, the optical components to distribute the light from the lamps, and the electrical components (ballast, starters, etc.) necessary to operate the lamps.

**luminance:** Commonly referred to as brightness, the light leaving a surface measured in footlamberts. It considers both *illuminance* on the surface and reflectance of the surface.

**luminance ratio:** The ratio between the *luminances* of any two areas in the visual field. This is a measure of the uniformity of luminance.

**maintenance:** An ongoing process to ensure equipment operates at peak performance.

**meter:** A device used to measure and display or record data.

**nitrogen oxides (NO<sub>x</sub>):** Chemical compounds that contain nitrogen and oxygen. They react with volatile organic compounds in the presence of heat and sunlight to form ozone and are a major precursor to acid rain.

**occupancy sensor:** A device that detects the presence or absence of occupants and controls operation of equipment accordingly.

**off-peak:** Refers to a utility rate schedule that designates the time of day when energy and demand costs typically are less expensive.

**on-peak:** Refers to a utility rate schedule that designates the time of day when energy and demand costs typically are more expensive.

**packaged unit:** A self-contained HVAC unit that provides heating and/or cooling to a building space.

**part-load:** The condition when equipment operates at less than full capacity to meet the demand placed upon it.

**part-load conditions:** Time when equipment is operating at less than design loads; represents the majority of the time equipment is operating.

**part-load performance:** Equipment efficiency at less than full capacity.

**payback, simple:** Also known as *payback*. Measurement of the elapsed time between an initial investment and the point at which accumulated savings are sufficient to offset the initial investment.

**payback:** See *payback, simple*.

**PCB:** Polychlorinated biphenyl; a substance used as an insulator in the capacitor of fluorescent and HID magnetic ballasts prior to 1970. PCBs have been labeled as carcinogenic and can cause skin, liver, and reproductive disorders.

**peak (cooling) load:** The maximum cooling required to maintain an indoor design temperature under the most adverse summertime outdoor air conditions.

**photocell:** A device that responds electrically to the presence of light.

**power factor:** The ratio of real power to total apparent power.

**power quality:** The degree to which voltage and current wave forms conform to a sinusoidal shape and are in synchronous phase with one another. Poor power quality can have negative impacts on electrical equipment.

**PPM:** Parts per million. A unit of concentration.

**pressure drop:** The loss in pressure experienced by flowing water or air due to friction and obstructions.

**pump, chilled-water:** A device that circulates chilled water.

**radiator:** A device that provides warmth to a space through radiant or convective heat provided by either steam or hot water.

**RCRA:** The Resource Conservation and Recovery Act (1976).

**recommissioning:** See *tune-up, building*.

**reflector:** A device installed in *luminaires* used to direct light from a source via specular or diffuse reflection.

**refrigerant:** A substance, such as CFCs, HCFCs, HFCs, air, ammonia, water, or carbon dioxide, used to provide cooling by evaporation and condensation.

**reset, chilled water:** The practice of increasing chilled water temperature to obtain higher chiller efficiency.

**reset, condenser water:** The practice of decreasing condenser water temperature to obtain higher chiller efficiency.

**rightsizing:** The process of correctly sizing equipment to the peak load.

**roof curb:** A raised and reinforced area on a roof for mounting equipment.

**rooftop unit:** Air-handling equipment such as *packaged units* located on the roof.

**scaling:** See *fouling*.

**schedule:** A control sequence that turns equipment on and off.

**seasonal energy-efficiency ratio (SEER):** Cooling capacity (Btu/hr) divided by total input power (watts) requirement where both are seasonal averages.

**SEER:** See *seasonal energy-efficiency ratio*.

**setpoint:** Desired temperature, humidity, or pressure in a space, duct, etc.

**sheave:** (Pronounced shiv.) Pulley.

**space:** The distinct area to which conditioned air is delivered.

**steam trap:** A device that separates air and condensed water from steam.

**strainer screen:** A filtering device used in water side systems to protect equipment from dirt, rust, and other particles.

**sulfur dioxide (SO<sub>2</sub>):** A heavy, colorless, pungent air pollutant formed primarily by the combustion of fossil fuels such as coal. It is a respiratory irritant and a precursor to the formation of acid rain.

**TAB:** See *testing, adjusting, and balancing*.

**testing, adjusting, and balancing (TAB):** The process of adjusting HVAC system components to supply air and water flows at design or revised specifications.

**thermostat:** A device that responds to temperature changes and controls equipment by seeking a setpoint accordingly.

**timeclock:** The control device used to turn equipment on and off at set times of the day.

**ton:** A unit of cooling capacity equal to 12,000 Btu/hr.

**transformer:** A device that reduces the incoming line voltage, usually to a standard level, so that it may be used to operate electrical equipment in a building.

**tubes, condenser:** Heat exchanger tubes through which condenser water is pumped to allow heat transfer between the condenser water and the refrigerant.

**tubes, evaporator:** Heat exchanger tubes through which chilled water is pumped to allow heat transfer between the chilled water and the refrigerant.

**tune-up, building:** The purposeful sequence of maintenance and operational improvements, undertaken at a specific point in time, designed to reduce energy use, heating loads, and cooling loads of existing facilities.

**variable air volume (VAV):** A type of air-handling system that maintains comfort in a building by varying the quantity of air supplied through the building.

**variable-speed drive (VSD):** A device used to adjust the speed of an air-conditioner motor to match load requirements.

**VAV:** See *variable air volume*.

**VCP:** See *visual comfort probability*.

**visual comfort probability (VCP):** A rating given to lighting systems expressed as the percentage of people who will be expected to find it acceptable in terms of glare discomfort.

**volts, voltage:** The international system unit of electric potential and electromotive force.

**VSD:** See *variable-speed drive*.

**W/sf:** Watts per square foot.

**water side systems:** Equipment used to heat, cool, and transport water to building HVAC systems.

# Energy-Efficiency Quicklist

This guide recommends a lot of different energy upgrades. Where should you start? First walk through your congregational facilities with this Quicklist in hand and use it to identify money-saving opportunities. Then post the Quicklist on your wall and check off items as you perform upgrades to keep track of your progress.

## Lighting



- Replace incandescent light bulbs with compact fluorescent lamps
- Convert exterior lighting to high-pressure sodium or metal halide lighting
- Upgrade fluorescent fixtures with T-8 fluorescent lamps and electronic ballasts
- Remove or disconnect unnecessary lights
- Convert exit signs to LED
- Lower light levels where appropriate, such as around computer monitors
- Install occupancy sensors in areas, such as bathrooms, that are frequently unoccupied
- Install timers or photocells on outside lights

## Water Use And Water Heating

- Install a water heater insulating blanket and wrap the first 3 to 6 feet of hot water supply pipe with pipe insulation
- Install faucet aerators and efficient showerheads
- Select native or other low-water plants for landscaping
- Find and fix leaks

## Refrigeration

- Repair doors and seals so they close tightly
- Make sure fans and equipment are not obstructed
- Combine refrigerated goods and disconnect unneeded refrigerators

## Building

- Install weather stripping, caulking, or seals on openings that create drafts
- Add or repair insulation to create a continuous blanket around building

## Heating And Cooling Systems

- Clean and replace filters regularly
- Set back your heating, ventilating, and air-conditioning (HVAC) systems when the building is unoccupied. This includes setting the fans to “auto” rather than “on”
- Repair leaks in system components such as pipes, steam traps, and couplings
- Make sure radiators, convectors, air intakes, and air diffusers are not obstructed so that air can flow freely
- Reduce your water heater settings to the minimum required temperature

# *ENERGY STAR Shopping List For Congregations*

**Buying or leasing a building with these preferred technologies can lower your operating costs. Use this list when walking through a prospective building. Call 1-888-STAR-YES if you have any questions.**

		Yes	No			Yes	No
<b>Lighting</b>				<b>Heating</b>			
<b>General</b>	T-8 Fluorescent Lamps	___	___	High-Efficiency Gas Furnace	___	___	
	Compact Fluorescent Lamps	___	___	Pulse Combustion Boiler	___	___	
	Occupancy Sensors	___	___	High-Efficiency Heat Pump	___	___	
	LED Exit Signs	___	___	Insulated Pipes/Ducts	___	___	
	Low-Glare Daylight	___	___	Ducts All Inside Building Envelope	___	___	
<b>Warehouse</b>	High-Pressure Sodium (HPS) Or Metal Halide (MH) Lighting	___	___	Electronic Ignition (No Pilot Light)	___	___	
<b>Retail</b>	Halogen	___	___	<b>Cooling</b>			
<b>Office</b>	Light Level Below 75 Foot-candles	___	___	Newer High-Efficiency Cooling Units	___	___	
	Deep-Cell Parabolic Fixtures	___	___	Economizers/"Free Cooling"	___	___	
<b>Exterior</b>	HPS Or MH	___	___	Coils Clean And Free of Moisture	___	___	
	Photocells or Timers	___	___	<b>Other</b>			
<b>Hot Water</b>				<b>Notes</b>			
	Insulated Pipes	___	___				
	Water Heater Insulating Blanket	___	___				
	Faucet Aerators	___	___				
	Efficient Showerheads	___	___				
	Solar Hot Water	___	___				
<b>Building</b>							
	Low-E Windows	___	___				
	Awnings To Block Summer Sun	___	___				
	Window Film	___	___				
	Roof Insulation	___	inches				
	Wall Insulation	___	inches				
	Tight-Closing Doors/Windows	___	___				
	Reflective Roof	___	___				
	Operable Windows	___	___				
<b>Heating And Cooling Distribution</b>							
	Energy Management System	___	___				
	Programmable Thermostats	___	___				
	Variable-Speed Drives	___	___				
	Energy-Efficient Motors	___	___				